

DOCUMENT RESUME

ED 210 026

IR 009 834

AUTHOR Meadow, Charles T.; And Others
 TITLE Individualized Instruction for Data Access (IIDA).
 Final Report.
 INSTITUTION Drexel Univ., Philadelphia, Pa. Graduate School of
 Library Science.; Franklin Inst. Research Labs.,
 Philadelphia, Pa.
 SPONS AGENCY National Science Foundation, Washington, D.C.
 PUB DATE 22 Oct 81
 GRANT NSF-DSI-77-26524
 NOTE 73p.; For related documents, see ED-201 340 and ED
 190 080-084.

EDRS PRICE MF01/PC03 Plus Postage.
 DESCRIPTORS *Computer Assisted Instruction; Computer Programs;
 Databases; Higher Education; Individualized
 Instruction; *Information Retrieval; *Man Machine
 Systems; *Online Systems; *Training Methods
 IDENTIFIERS *Individualized Instruction for Data Access;
 *Users

ABSTRACT

The realization that the facilities available for the retrieval of scientific and technical information were being underutilized resulted in a project undertaken by the Drexel University School of Library and Information Science to develop a computer intermediary capable of assisting users of scientific and technical information in the performance of online bibliographic searches. Individualized Instruction for Data Access (IIDA), the computer system developed during the project, operates in an instructional and an assistance mode, and can be used to train users to perform online searches or to aid users in search performance. The system employs a set of diagnostics which alert users to the strategic and syntactic errors they make during the search process. When IIDA was operational, a number of evaluations of the system were made, using first undergraduate computer science majors and experienced online searchers, then library science faculty and graduate students and undergraduate engineering students, and finally engineers at the Exxon Research facility in Florham Park, New Jersey. The evaluation studies indicated that individuals who had never done online searching were able, using IIDA, to do searches which produced satisfactory results. Detailed accounts of the design of the system, system operations, and the methodology of the evaluation studies are given, and the project bibliography is included. (JL)

 * Reproductions supplied by EDRS are the best that can be made *
 * from the original document. *

U.S. DEPARTMENT OF EDUCATION
NATIONAL INSTITUTE OF EDUCATION
EDUCATIONAL RESOURCES INFORMATION
CENTER (ERIC)

This document has been reproduced as received from the person or organization originating it.
Minor changes have been made to improve reproduction quality.

Points of view or opinions stated in this document do not necessarily represent official NIE position or policy.

INDIVIDUALIZED INSTRUCTION FOR DATA ACCESS
(IIDA)

Final Report
October 22, 1981

Charles T. Meadow
Thomas T. Hewett
Elizabeth S. Aversa

Drexel University, School of Library
and Information Science
Franklin Institute Research Laboratories

NSF Grant No. DSI 77-26524

PERMISSION TO REPRODUCE THIS
MATERIAL HAS BEEN GRANTED BY

Paul Meadow

TO THE EDUCATIONAL RESOURCES
INFORMATION CENTER (ERIC).

ED210026

IR009834

TABLE OF CONTENTS

1) Summary -	1
2) Purpose of IIDA -	4
3) General Description of IIDA -	6
4) Assumptions and Constraints in IIDA Development	9
5) Overview of System Design -	10
5.1 Instruction Mode -	11
5.2 Assistance Mode -	12
5.3 Help Facilities -	14
5.4 Post-Search Summary -	15
5.5 Software Components -	16
5.5.1 The communications interface -	16
5.5.2 The parser -	16
5.5.3 The diagnostic procedures -	18
5.5.4 The warning control program -	18
5.5.5 The instructional programs -	19
5.5.6 The help program -	20
5.5.7 The post-search summary -	20
6) How IIDA Operates -	21
6.1 Introduction to IIDA -	21
6.2 Exercise Mode -	22
6.2.1 Exercise 1 -	22
6.2.2 Exercise 2 -	23
6.2.3 Exercise 3 -	25
6.3 Assistance Mode -	27
6.3.1 User-initiated help -	27
6.3.2 IIDA-initiated assistance -	29
7) Relationship of IIDA to Other Systems -	31
8) Evaluation -	35
8.1 First Stage Evaluation -	35
8.1.1 Project staff evaluation -	35
8.1.2 Computer science majors -	35
8.1.3 "Real" searches -	36
8.1.4 Library and Information Science faculty and graduate students	36

TABLE OF CONTENTS

(continued)

8.2	Second Stage Evaluation -	37
8.2.1	IIDA as assistant -	37
8.2.2	IIDA as instructor -	39
8.2.3	Discussion -	41
8.3	Third Stage Evaluation -	43
8.3.1	Baseline study -	44
8.3.2	Training method study -	47
8.4	General Discussion -	49
9)	Search Characteristics -	54
9.1	A Search as a Markov Process -	54
9.2	Other Characteristics of a Search -	57
10)	The Future of Computer Assistants -	58
10.1	Matching Users and Programs -	58
10.2	The Role of Intermediary Programs -	59
10.3	Impact of Intermediary Computers -	60
11)	Acknowledgements -	62
12)	IIDA Bibliography -	64
13)	References -	66

1. SUMMARY

Beginning in 1976 a project was undertaken by the Drexel University School of Library and Information Science and the Franklin Research Center with the objective of providing a computer intermediary to aid scientific and technical users of online bibliographic information retrieval systems in the performance of data base searches. The project was undertaken out of recognition that the facilities available for searching and disseminating scientific and technical information were being underutilized and that helping the people who would normally be expected to benefit from this information would encourage them to become, and to remain, users of these facilities.

Technically, the problem of developing a computer intermediary was one of monitoring the conversation between a user and the information retrieval system, or search service. The complexity of a bibliographic search is exacerbated by the searcher's uncertainty, at the start, as to what information exists on the desired topic, if any. Further, the definition of "desired topic" is likely to change during the search as a result of probing early in the search. Feedback, positive and negative, will affect the user's future decisions. Given the degree of uncertainty in a bibliographic search, a computer program whose function it is to assist a user in performing a search, and whose information is restricted to what it can gain by monitoring or by initiating its own questions to the data base, can not "know" how to do the search. It can, at best, tell when the human user makes a mistake and it can offer general advice on how to proceed.

Working under these conditions, we developed a system called Individualized Instruction for Data Access (IIDA). IIDA is able both to teach a novice searcher how to search and to assist him in doing so. It is individualized in two senses: users may take instruction at a time of their own choosing and their own pace; and, when used as an assistant, IIDA's messages to the user are a direct function of what the user has done in the search. Emphasis has been on assistance, always with the assumption that we have a relatively inexperienced searcher working in a problem-solving situation.

IIDA, as a computer software system, resides in a computer separate from that of the search service. While the original design called for this to be a dedicated mini-computer, our experimental implementation was done on a large time shared computer, for economic reasons. Users would send their search commands to this computer which would relay them to the search service, and then receive and relay the search service's reply. A complete history of the search is then maintained.

Before beginning a search, an IIDA user has the option of taking some computer assisted instruction on how to search. Administration of instruction is done by IIDA in its instructional mode. When the user is ready to begin an actual search, he deals with IIDA in assistance mode. It is in this mode that IIDA serves as monitor, relays messages between user and search service and performs a continuing analysis of the search in progress. IIDA makes its presence known to the user only upon his request or upon its discovery of a problem that implies help may be needed. The heart of the search analysis is performed by a set of diagnostic procedures, which are concerned with everything from fatal syntactic errors (i.e., entry of invalid commands) to procedural usages that cannot be decisively classified as either correct or incorrect, but may be indicative of a problem to come.

Since the intended user of IIDA is the working scientist or engineer, we felt it necessary to evaluate the system's performance in teaching and assisting such persons, and to do so on a scale large enough to be convincing. Several preliminary tests were conducted with various student and faculty groups at Drexel University, but the main evaluation studies made use of 100 scientists and engineers of the Exxon Research and Engineering Company.

In brief, the evaluation studies tested the performance of IIDA in an industrial setting quite like that envisioned as the appropriate IIDA environment. The results show that: IIDA trained and assisted users produced search results that were satisfactory to them. We can draw the conclusion from our tests that the concept "works" in that it enables the novice (to searching) end user of scientific and technical information to perform his own searches at an acceptable level of competence.

In this report, we survey the design of IIDA system (sections 2 through 5), describe how it operates from the user's perspective (section 6), relate it to other research programs (section 7), describe the evaluation program (sections 8 and 9), project how IIDA and systems like it will evolve and what impact they will have in the future (section 10), acknowledge the help of many people (section 11), and list a bibliography of project-related publications (section 12).

2. PURPOSE OF IIDA

IIDA was developed for two purposes. Its original primary purpose was to increase the use of existing scientific and technical information resources by those who currently do not use them, or under-utilize them. The second purpose was to investigate the feasibility and effectiveness of a particular approach to that objective, which involved research into the nature of the activity of interactive bibliographic searching, and development of measures of user performance.

At the inception of the project, we undertook to develop an operational system to teach and assist end users to make use of bibliographic information retrieval systems. This system was to be operated as a service to all interested users. At the conclusion of the project's first year, a change in priorities at the National Science Foundation resulted in a reorientation of the project more toward research into how searching is performed, and how well a teaching-assistant system could be made to perform, but with no intent to provide more than an experimental version of the system.

To be more explicit, the IIDA system, in concept, has as its objective to enable end users of bibliographic information to perform their own searches under certain circumstances, described in Section 4. This was to be done by both teaching them how to search and assisting them while searching. Inherent in this objective is a limitation on the nature of the search objective, generally to something like a few good references, rather than an exhaustive bibliography or the single "best" citation on a topic.

This goal was justified on the grounds that there were a large number of scientific and technical persons who were not using or who were under-using the resources made available to them (1), often at high cost, and by the assumption that users could do many of their own searches. The result was expected to be more searching overall, and a tendency to apply the time of professional searchers to the more difficult cases (2). While it is impossible to document formally, we note that we felt an attitude of almost

hostility on the part of many professional searchers or intermediaries when we first publicly announced our goals for IIDA in 1976, but that recently, say from 1979 on, this idea has seemed to us to have caught on and become accepted by the information science community. We do not attribute the change in attitude solely to our own project. More likely, we feel, it is an idea whose time has come.

3. GENERAL DESCRIPTION OF IIDA

IIDA is a computer system that serves as an intermediary between the user of an interactive information retrieval system and the system itself. It operates in two main modes, instructional and assistance.

In the instructional mode, IIDA teaches a user how to perform a search, using rather primitive computer assisted instruction. Although there are practice searches interspersed with the instructional material, the two are distinct--all instruction is pre-use instruction in the sense that material is taught in one segment of the instruction and practiced in the next segment. The practice searches, however, are real, not "canned."

In the assistance mode, IIDA helps the user in the performance of a real search. It is this mode which is the major innovation and the principal focus of the research. When operating in this mode, IIDA is an example of a new class of computer assistants or coaches, as defined by Goldstein (3).

Mechanically, IIDA consists of a set of computer programs resident in a computer with which the user is in communication (see Figure 1). The IIDA computer, in turn, communicates with the information retrieval or search service, computer (4). Users deal only with the DIALOG language; IIDA does not supply its own language or extra search commands. Our original assumption was that if the value of an assistant could be proven with one representative language, it would be reasonable to assume it is valuable for other languages of a similar nature. Near the end of the project, some effort was devoted to developing some new commands aimed at helping the user find some search terms (5). Several commands were implemented on an experimental basis, and given a preliminary test of performance with inconclusive results.

While conducting a search, the user enters commands through IIDA, but using the DIALOG language, and normally receives the same responses he would if dealing directly with DIALOG. IIDA monitors the conversation, examining both commands and responses, looking for errors or indications of problems or

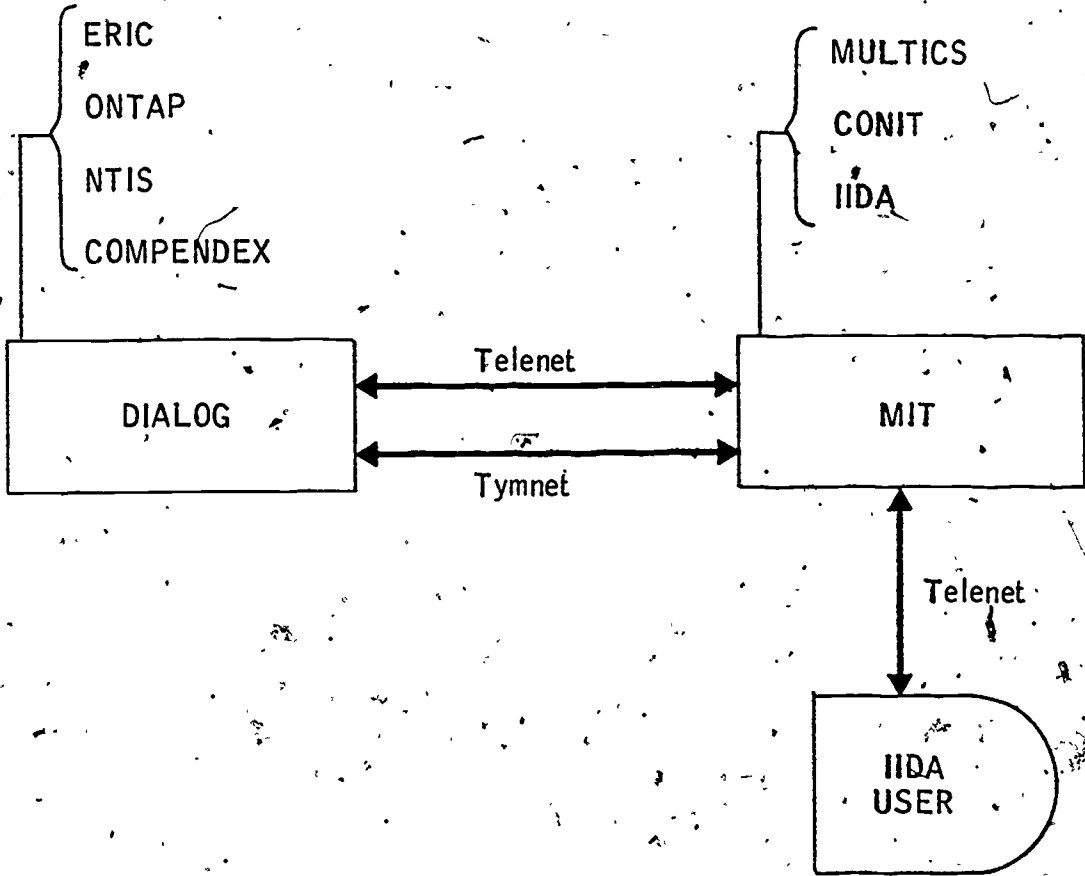

Figure 1. IIDA GENERAL CONFIGURATION

potential problems. When any of these is detected, IIDA offers abundant, voluntary help facilities, tailored to the specific problem at hand, and might, for example, offer to refresh a searcher's memory on the use of a command in which a syntax error was just made.

IIDA is required, then, to monitor and appraise the performance of a search, and to intervene when a problem is detected. Intervention is in the form of: (1) informing the user of the nature of the problem, (2) offering advice on what to do next, and, (3) offering a reminder of what reference information is available concerning this specific problem. For example, if the error is a syntactic one, its nature will be explained, and the appropriate page number of reference material given to the user. If the error were a procedural one, rather than syntactic--for example, creation of too many null sets, advice on proceeding may be offered as well.

Because the searches are real, IIDA cannot know in advance what the user's search objective is, or the best way to go about the search. Hence, it is limited to observation of what the user does, and what results he achieves--it has no more information available to it than he does, himself. Obviously, then, there are few clear "right" or "wrong" procedures, except for the minimal requirement of command syntax. The challenge of designing an assistant for bibliographic searching lies therein.

4. ASSUMPTIONS AND CONSTRAINTS IN IIDA DEVELOPMENT

IIDA was designed with a specific user population in mind. Although it has some utility for other groups, the initial design was predicated on the following user characteristics:

1. Users have some technical or disciplinary training or education, in the sense that they are aware of a specialized vocabulary within their own profession.
2. Although not trained in documentation, they are aware of the existence of a professional literature, and of the concept of citations and abstracts.
3. Although not necessarily trained in computer use, they are at least not computer-shy, f.e., they have probably used computers or computer output, or participated in planning computer projects, and are not made anxious by the prospect of hands-on use.
4. Their objective in using the system is serious, as contrasted with someone who might use a computer system merely to learn to discover its faults, or to "bug" it. IIDA users are presumed to be solving a problem of their own when using the system.
5. Use will be Occasional, perhaps one to ten times per year. The implication of this assumption is that infrequent users of artificial languages tend to forget details, and need frequent refresher instruction.
6. Search objectives will be limited. IIDA users are unlikely to be performing patent searches or exhaustive searches of any kind. They are more likely looking for a few "good" citations, or a good general bibliography.

5. OVERVIEW OF SYSTEM DESIGN

As noted earlier, IIDA is resident in a different computer than is the information retrieval system. Users dial IIDA, via Telenet, and log into its computer, which is the Multics time sharing computer at Massachusetts Institute of Technology. In the experimental implementation of IIDA, the Multics log-in procedure was slightly more complex than that of DIALOG. Originally, IIDA was intended to reside in a dedicated minicomputer, which would have made log-in considerably simpler.

The instructional programs are resident with IIDA. When the user is in instructional mode, he is not in telephone connection with DIALOG, which, of course, means that instruction costs less per connect hour than searching.

The data bases used with DIALOG in experimental work were ERIC, ERIC ONTAP, NTIS, and COMPENDEX. IIDA is both data base and search service dependent. It would typically require about one man-day of effort to add a new data base to IIDA's DIALOG repertoire, and perhaps three man-months to link IIDA to a different search service. The latter requires a complete new set of command and response parsing programs, and a different communications interface. Each search service might, for example, have a different way of indicating the end of a message. On the other hand, adding a new DIALOG data base merely requires a table indicating the location within a citation record of each field.

When conceived of as resident in a dedicated minicomputer, IIDA was planned to be able to handle 12 to 15 simultaneous users, the exact number depending on the speed and memory capacity of the computer selected. In the experimental implementation, hardware limitations permitted at most 2 users at a time, often only 1. In a multi-user version, users would have a line between IIDA and the search service, IIDA acting then as a concentrator or multiplexor. A planned commercial version of IIDA, to be produced by the Franklin Institute Research Laboratories, Inc. will incorporate this original design feature.

5.1 Instruction Mode

IIDA's two operating modes are distinct--a user is clearly in one or the other. The instructional mode consists of two teaching programs, each followed by a practice search.

The first exercise (6) is a computer assisted instruction program. Its purpose is to introduce the student user to the minimal set of DIALOG commands necessary to perform a meaningful search. The commands introduced are: BEGIN, EXPAND, PAGE (needed with EXPAND), SELECT (for single terms only), COMBINE, TYPE, and LOGOFF. All IIDA experiments involved use of print terminals only, hence the DISPLAY command was not needed. A simplified form of computer assisted instruction is used to administer this exercise. As each command is introduced, the student is asked to type in the command, following exactly an example given to him. If it is typed correctly, he sees a replica of the DIALOG response to the command. He is expected to discover for himself the gist of what the command does. The full explanation of the command follows, rather than precedes, this example, to maximize self-learning. Boredom of the user was expected to be a possible problem, and early pilot tests bore out that it was. They do not, in general, want wordy explanations of something that is self-evident.

The user is taken, in this fashion, through a complete sample search. At its end, it is suggested that he try a search of his own. This is exercise 2. Now, IIDA links itself to DIALOG, suggests a search topic to the student, and then puts itself into assistance mode. The search topic used in experiments was one tried out by the research staff beforehand, and designed to be highly likely to result in a success.

Exercise 3 reverts back to the presentation of instructional material. It covers a variety of advanced topics, including more commands and search strategy. Because it would take about one hour to type out all this instruction, when a student enters exercise 3, he is given only the introduction to each of the following topics, but he must go through this minimal material:

1. Review of basic commands
2. Advanced commands
3. Text searching
4. Search strategy
5. Data base descriptions
6. Beginning and ending the search
7. IIDA facilities

The idea behind this approach is to tell the user that information on these topics exists, and to invite him to explore further at his leisure. After completing this brief "reference walk," he is free to go on to the next exercise or to go back to any topic of his choice and explore it in as much detail as he wishes. The reference walk takes about eight minutes. The browsing time in the complete set of exercise 3 material is a function of the user.

Exercise 4 consists simply of the student performing another search, this time of his own choosing.

2.2 Assistance Mode

In assistance mode, the user performs a DIALOG search, and it is IIDA's objective to provide assistance to him in doing so. Assistance is based on the following principles:

1. It is, of course, not possible for IIDA to "know" how the search should be conducted, since each user is the sole judge of the applicability of results to his own objective, and because the contents of data bases change with time. Thus, even if a question has been searched before, a different searcher uses a different data base, and has different perceptions of success.
2. As a result, IIDA is a reactive system. It cannot tell the user how to perform the search, but it can detect various errors and poor usages, and can offer general advice on how to proceed, in the context of the error discovered.

3. In order to detect errors and poor usage, IIDA employs a set of diagnostic procedures, which are grouped into three classes:

a. Syntactic. IIDA will detect any error in DIALOG syntax.

IIDA provides the user as much information as possible about the nature of the error, e.g., not simply the notation "syntax error," but a clear statement of what part of the input command is acceptable and what part not, including what IIDA assumed to have been the command. For example, if a user entered the command TYPE 3/6/2, DIALOG would assume this to be a TYPE command, from the initial letter. It would then expect the next character to be a set number and, not finding one, would declare the command invalid. IIDA would state the assumed command, and state that from "YPE" on, the argument of the command is invalid, and that a set number was expected after "T." Neither IIDA nor DIALOG tries to correct the error.

b. Procedural Error--Single Command. This group of diagnostics is concerned with commands which pass the syntactic analysis, but, when examined in the context of the history of the search to date, are found to be faulty to some extent. The faults can range from fatal, as in the case of an invalid set number (e.g., COMBINE 3 and 4, but set 4 has not been defined), to minor (e.g., repetition of a command).

c. Procedural Error--Strings. These diagnostics are concerned with strings of commands. A string is defined as an unbroken series of commands of the same type. An example of such a diagnostic is a test for string length. If a user enters more than five consecutive COMBINE commands, a diagnostic is "triggered," which need do no more than to suggest that he consider doing something different.

4. Each time a diagnostic detects a fault:

- a. A statement is sent to the user describing the fault. This message is terse and emotionally neutral.
- b. A record of the occurrence of the fault is made in a search history file. This file is then used for interpreting later commands. It will, for example, contain a list of numbers of the sets created, and hence provides the basis for deciding whether a set number in a command is valid.
- c. In many cases, the user is offered "quick advice," i.e., a suggested action based on the type of error made, not the specifics of the command. An example is that after an excessive number of COMBINE commands has triggered a string length diagnostic, the advice will be to try printing some of the records to get an idea of their contents, rather than defining so many new sets.
- d. In all cases, the user is referred to a reference number in the exercise 3 library of instructional material, which identifies a page or frame of tutorial material relevant to the error just made. For example, if a syntactic error has been detected, the reference will be to a frame describing the syntactic rules for this command type.

The complete set of diagnostics is documented in Quarterly Report 4 (7). A discussion of how well these performed, when viewed as a measure of user performance, is found in (8).

5.3 Help Facilities

Like most on-line systems, IIDA has a HELP facility. The user may enter the command/HELP* at any time. He is then given the option of entering the help library (actually the library of frames for exercise 3), or viewing

* Following a common programming practice, we use the character "/" preceding a command to distinguish this use of the word "help" from any other use.

any of several summaries of his search so far (commands used, sets created, records viewed, errors made, or terms used), or of returning to the search or to one of the exercises. Quick advice, described above, is also a help option.

A shorthand notation, /HN, where n is a page or frame number in the reference library, enables the user to go directly from a search to that frame, without first calling for /HELP and seeing the help menu of services offered.

In addition to the option of returning to the search, a user may exit from HELP at any time by entering a valid DIALOG command.

5.4 Post-Search Summary

Going back to the original design concept for IIDA, it had been planned that IIDA would operate out of a dedicated minicomputer, with up to 12-15 simultaneous users. To support this operation, there was to be a proctor who would be located physically near the computer, and accessible to users either by message through the user's terminal or by telephone. The proctor would be charged with providing whatever help a user needed, ranging from coping with the mechanics of the terminal to advice on search strategy. To assist the proctor, he would be supported by a high speed terminal, and would have access to the history files of any user. Thus, if called by a user, or if called by IIDA because of an excessive number of diagnostics, the proctor could quickly review the history and status of the search (23).

When we implemented IIDA in its experimental form, because of hardware limitations, it was never possible for more than 2 people to use it at one time, and our experimental procedures were such that these would always be working through our own terminals under controlled conditions. Hence, we did not need the proctor. However, the history tables developed around the idea of a proctor were still thought to be useful, and proved to be so.

They could be used as reference aids by searchers, through the help facility. This option was seldom, if ever, invoked in our tests. They proved invaluable to the IIDA research staff in preparing data for statistical analysis. Examples of the tables are shown in (9).

5.5 Software Components

From a computer software point of view, the main components of IIDA are: (1) a communications interface, (2) a parser, (3) the diagnostic procedures, (4) the warning control program, (5) the instructional programs, (6) the help programs, and (7) the post-search summary. These are summarized below, and are explained in greater detail in Quarterly Report 6 (10). The approximate relationship among the programs is illustrated in Figure 2.

5.5.1 The Communications Interface. The purpose of this program is to handle the passing of messages in either direction between the IIDA computer and the user's terminal, or the search service computer. The Multics computer has an automatic dial-out device, called an autocall, which initiates the outgoing telephone call from the computer to the TELENET or TYMNET networks in order to reach DIALOG. Incoming messages from DIALOG pose a particular problem because they arrive in fragments, and do not contain an explicit end-of-message indicator. Hence, the program is sometimes not certain when a message, rather than merely a packet, has ended. For example, a long abstract may consist of several packets, and the IIDA communications interface gets no explicit signal from DIALOG that the abstract has ended. A timing device can be used, but sometimes network delays made it appear that the end of a message has been reached when it has not, and the result is cutting the user off in mid-message. Certain messages have known endings (e.g., the response to an EXPAND ends in "-MORE-"), but the end of a response to a TYPE command cannot always be detected. Thus, the success of a system such as IIDA depends upon its ability to keep the flow of messages moving smoothly, and to inform the user when there has been an interruption or delay beyond the capability of IIDA to control.

5.5.2 The Parser. The parser must parse, or separate into syntactic components, the user's input, the search service's responses, and the network's occasional messages that may interrupt the flow of user-search service traffic. On messages from the search service or the network, the parser recognizes the component parts. On messages from the user, the parser also checks for syntactic validity. Although it is logically desirable for parsing and validity checking to be separate functions, it is not always

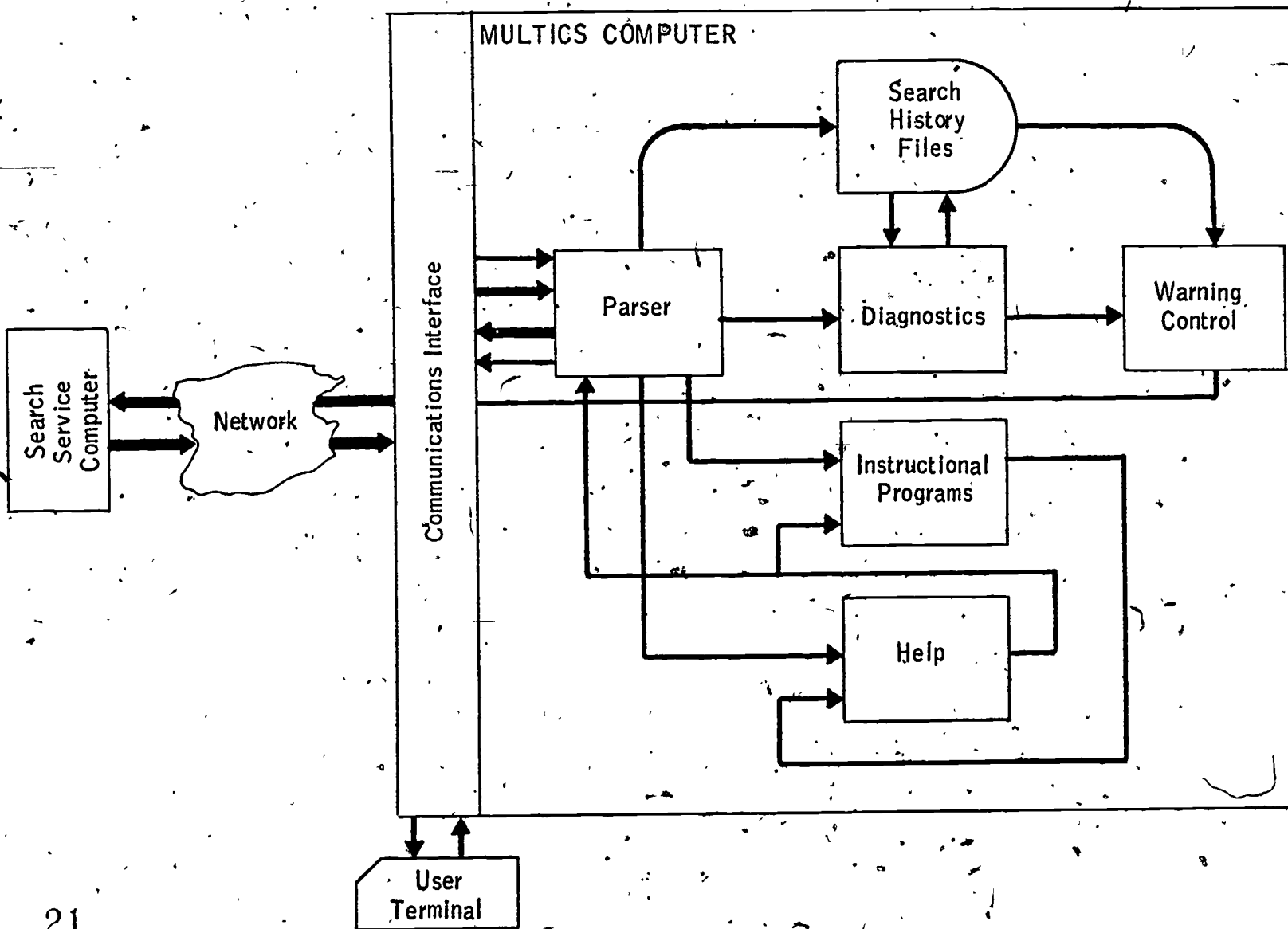

Figure 2. IIDA SOFTWARE CONFIGURATION

possible, because recognition of succeeding syntactic elements depends on preceding elements. Thus validity checking must go on as the parsing goes on.

Parsing is highly dependent on the search language and on the composition of messages received from the search service. Changes in language or in search service responses, such as are occasioned by introducing a new search service, make for major changes to IIDA, while changing the system to accommodate another data base offered by the search service for which programmed is a relatively minor problem, because only the data record structure changes, not the command language or repertoire of response messages.

Both the parser and the communications interface, as actually implemented, were heavily dependent upon software developed by Marcus and Reintjes for the CONIT project (13).

5.5.3 The Diagnostic Procedures. Once the parser has broken a command and its response into their elementary syntactic components and added these to appropriate tables describing the history of the search, each diagnostic rule, as software, is little more than a complex PL/I IF statement. The design principle here was to use the diagnostic rule (IF statement--RULE has about the same meaning it has in the decision table context) to determine what rules were violated, and then, in a separate action, decide what to do about it, or them. Both the parser and the diagnostics use and maintain the search history files.

5.5.4 The Warning Control Program. A diagnostic rule signals warning control that a rule has been violated. Warning control decides what messages to send to the user as a result. In its initial design, warning control performed two prime functions. First, if more than one rule was violated by a single command or its response, warning control decided to which rule violation to respond. The general principle was to respond to the most specific. For example, if a user violated both a dwelling (too many similar COMBINE commands, with similar results) and a string length rule with the same command, warning control would respond to the dwelling rule violation, as the more specific, hence probably the more valuable for the user to know about. The second function of warning control was to be concerned with the frequency

of diagnostic messages to the user (or warning messages, hence the name). In some cases, a rule was not violated until some error had occurred more than n times, for example the generation of a null set. Generating a null set does not, in itself, trigger a diagnostic reply from IIDA, but generating several of them does. On the other hand, once a warning or diagnostic message is given, and the error recurs immediately thereafter, the designers felt there would be no point in immediately repeating the diagnostic message. For example, if a string length error occurs, a diagnostic message is sent, but if the user adds another command to the same string, there is no point reminding him again of the string length problem. Instead, IIDA would suppress messages responding to this particular error until the condition recurred m times. The variables n and m were given arbitrary values, with the intent that experimental experience would lead to better settings. If, after a given rule had been suppressed once, it then was permitted to be used, i.e., the recurrence frequency m had been exceeded, the message would be enhanced with some reminder that the user had seen this message before. The objective was to enhance without nagging.

A later version of warning control made the resetting of thresholds a variable, and made available a command for the user to reduce the frequency of occurrence of diagnostic messages. If the user gave the command/SLACK after any diagnostic message, then the threshold for the rule that produced that message would be changed and made less stringent. This would enable a user who was violating IIDA rules but felt he knew what he was doing to proceed without interruption. In our experiments, this facility was never used, and we now deem it to have been elaborate than the situation calls for.

5.5.5 The Instructional Programs. The instructional programs of exercise 1 and 3 are a simple form of computer assisted instruction. In exercise 1, there is no variation of the sequence of instructional frames. All students are taken through the same material in the same order. Users are asked to enter commands, but they are to enter a command exactly as provided by the instructional frame preceding. In the event of any error, the user is asked to re-enter the command. This approach was taken in the interest of quick implementation, since the CAI was not the focus of our experimental work, but it was deemed important to have it in order to test the entire system concept.

In exercise 3, the user has a choice of material (except the first time through, when he must view only the major topic descriptions). However, no questions about substance are asked. The facility is primarily used, after the quick "reference walk," as a voluntary reference tool.

5.5.6 The Help Program. Help is almost a control program. Upon invoking HELP, the user is given an option of changing IIDA modes, i.e., entering into any exercise, starting or restarting a search, or of directly going to a message deemed by the diagnostic programs to be relevant to the most recent command and its result. In the latter cases, many diagnostic messages offer a reference number in the exercise 3 library of instructional frames that is specific to the error just detected. Also, in many cases, quick advice is offered, again in terms of a pre-stored message deemed by the diagnostics to be relevant to the current situation. Thus, HELP, as a program, is really one which switches the user to another program of choice.

Again, in the interest of both development and program running time, no attempt was made to provide for IIDA to directly answer user initiated questions. Rather, the user is told where information may be found, and he is then expected to find it.

5.5.7 The Post-Search Summary. As noted earlier, the post-search summary is merely a printing out of the search history tables used during the conduct of the search to assist the diagnostic process, and were originally planned for use by a proctor.

6. HOW IIDA OPERATES

The first-time user of IIDA generally begins with exercise mode in order to learn the basics of on-line searching. After learning the basic commands and becoming accustomed to the system, the user selects assistance mode and performs his DIALOG search in the ordinary way, except that IIDA informs him of errors and offers an extensive HELP program which is available during the search. The user is instructed on how to use the IIDA facilities (the HELP program and diagnostics) during the exercise or training phase of his IIDA experience. Each time the user logs on, he is offered a review of the commands and procedures unique to IIDA.

6.1 Introduction to IIDA

The user's first session begins with an introduction to the terminal and login procedures. During development and testing, assistants were on hand to get users started. The assistant dialed the local TELENET or TYMNET number, initiated IIDA's identification procedures, and completed necessary protocol to connect the user to the Multics system. During this activity, the assistant instructed the user in how to send a message "to the computer" if the user had had no experience with terminals. The user was then given a personal identification number, and was instructed to "enter your number when IIDA asks for it." The user was then on his own with IIDA.

The instructional exercises of IIDA are structured in individual frames of information of varying length. After each frame, the user is asked to enter a command, answer a question, or otherwise send a message to IIDA.

The user, after completing login procedures, is offered introductory frames on the IIDA system. Four frames, which explain the purpose of IIDA, some basic information on on-line searching, the components of the programs, how to correct an input error, and the use of the HELP program, are available to the user each time he logs on. He may see the entire introduction by answering "YES" to the question, "Would you like more information about IIDA?" which follows the first three frames. Upon completion of the introductory frames, or upon answering "NO" to any of IIDA's offers of introductory material, the user is shown a menu of options and is asked to select one.

To begin one of the following enter its number:

- Exercise 1: basic DIALOG commands
- Exercise 2: practice DIALOG search
- Exercise 3: advanced commands and search strategy
- Exercise 4: search assistance only

Enter '/done' if you are finished with IIDA.
I? 1

The user enters the number of the exercise or mode he wishes to begin. He may exit the program altogether by entering the response/done.

6.2 Exercise Mode

Exercise Mode consists of three parts: exercise 1 introduces the user to seven basic DIALOG commands and the IIDA HELP command; exercise 2 provides an opportunity for the user to conduct a simple search using the commands learned in exercise 1; and exercise 3 presents additional detail on the use of the basic commands, an introduction to advanced commands and practices used by experienced searchers, and brief descriptions of the data bases available through IIDA. An in-depth presentation of the use of the IIDA facilities and of search strategies is also included in exercise 3.

6.2.1 Exercise 1. Exercise 1 uses a simulation of a search in COMPENDEX (file 8) to teach the basic DIALOG commands. The "canned" search is on the use of solar energy to heat residential buildings. The system introduces the user to basic concepts of on-line searching, presents the search topic, and then tells the user what he is to do during the exercise.

We're now going to take you through a simple search. The subject of the search is the use of solar collectors or heat pumps in residential buildings. You'll be told what to type. Type in exactly what you're told and then you'll see what DIALOG does with that command. Later on, you can do a search of your own.

Enter BEGIN 8

D? begin 8

21nov79 11:40:51 User 9002

\$0.18 0.012 Hrs File1*

File8:COMPENDEX 70-79/AUG

(copr. Engineering Index Inc.)

Set Items Description (+=OR; *=AND; -=NOT)

From the initial BEGIN command to the end of the search, IIDA instructs the user to enter commands and to view the system's response. Following each response, IIDA describes briefly what each command meant and what the responses mean in terms of the search as a whole.

By the end of exercise 1, which takes about 20 minutes to complete, the user is familiar with the DIALOG commands BEGIN, EXPAND, SELECT, COMBINE, TYPE, PAGE, and LOGOFF, and with IIDA's HELP command.

Upon completion of exercise 1, the user is offered the menu of exercises and modes, and is free to choose an option or leave the system entirely.

6.2.2 Exercise 2. Exercise 2 is a practice search which enables the user to use the commands and techniques he learned in exercise 1. Two search topics are introduced. These are offered specifically as both subjects are extensively covered in the data base; IIDA's intent is to assure the novice user considerable success in his first search

Exercise 2 allows you to practice searching on DIALOG. It is possible to perform a successful search on a rather specific topic using only the six basic commands learned in Exercise 1. Practice your search skills by finding citations on one of the following topics using COMPENDEX (file 8);

1. Asphalt paving for road and bridge surfaces
2. Passive solar energy used to heat residential buildings

In this practice exercise you should try various approaches to searching while directing your efforts to the goals specified above. In the future, determine before beginning to search whether you are looking for a few relevant items on the subject or whether you are after an exhaustive bibliography.

Take a moment to think of some terms which are likely to appear in citations on the topic you have chosen. Note terms which you will use in developing your search. For example, you might plan to EXPAND the term 'solar' to see terms useful in a search on 'solar heating'. Also consider EXPANDING the term 'asphalt' for terms which may be useful in a search on 'asphalt paving.'

The user is asked to specify the number of items he wants to retrieve; this information is used later by diagnostics concerned with search results.

The user is told that "IIDA will place a telephone call to the DIALOG system" and that procedure will take a minute or two.

IIDA handles the entire logon procedure without input from the user. However, because the procedure does take a few minutes to complete, the user is informed of the initialization and status of telecommunication processes, the fact that the DIALOG logon procedure has been completed or aborted, and whether or not another attempt to connect to DIALOG has been initiated. After an unsuccessful attempt to login to DIALOG, the user may leave the system entirely or try again immediately. If his attempt is successful, IIDA tells him to start his search by using the BEGIN command with the number of the appropriate file.

```
Logging onto DIALOG
News from DIALOG:
wwwwww LOGON File1 Tue 20nov79 16:25:32 Port04E
FILES 3 and 16 ARE OFFLINE . . .
  DIALOG AVAIL. REGULAR HOURS DURING U.S.
  THANKSGIVING HOLIDAY PERIOD.
  REGISTER ONLINE FOR BEST OF UPDATE IN
  LONDON ON DECEMBER 7. SEE ?NEWS.
  NEW DISCLOSURE (FILE 100) NOW AVAILABLE
  WITH HALF HOUR FREE CONNECT TIME IN NOV
  WHITE HOUSE CONF. HOTLINE (FILE 202).
You are now connected to Lockheed DIALOG retrieval system--
Choose data base 1, 6, 8, or 201 with the BEGIN command.
```

```
D? beginl
  20nov79 16:25:59 User 7303
  $0.14 0.009 Hrs Filel*
  Filel*:ERIC 66-79/OCT
  Set Items Description (+=OR;*=AND;-=NOT)
```

The user carries out his search in the usual manner, and IIDA is available as an assistant through the HELP program, and as a monitor of the messages the user sends. If a syntactic error is detected, IIDA tells the user that an error was made, and gives the frame number for the HELP program. The user is not forced to use HELP, as many errors are apparent upon receipt of the error message. IIDA also asks the user to rate the relevance of citations typed out. This rating is used for several purposes: first, IIDA converses with the user on his progress in terms of relevance. Secondly, IIDA

can inform the user that his search may be nearly complete if, at some point, he has typed a fair number of highly relevant citations. Finally, the rating of the relevance of individual citations forces the user to think about what citations he has retrieved, and to look for concepts that he has not included in his search. In essence, the user is operating as if he were in assistance mode in exercise 2; the instructional features of the exercise are that the user is prompted to think about his topic and appropriate search terms before accessing DIALOG, he is given a choice of very specific topics to search, he is forced to consider the citations retrieved in terms of relevance, and he is given another chance to learn by doing.

6.2.3 Exercise 3. Exercise 3 serves two purposes: first, it is an instructional program, and secondly, its contents comprise the HELP library which may be accessed when the user is searching in assistance mode.

When the user selects exercise 3 from the menu of exercises or modes, he first sees eight frames of information. The first frame introduces the user to the exercise, and the remaining seven serve as a table of contents for the remaining 88 frames of information. The seven categories of instruction are listed in the illustration below:

Contents of Instructional Units

- a (1) Review of Basic Commands
 - begin, expand, select, page, combine, type, logoff
- b (2) Advanced Commands
 - file selection, limiting, type and print, abbreviation, time-saving techniques, search save
- c (3) Test Searching
 - searching for words or phrases embedded in larger sentences or paragraphs
- d (4) Search Strategy
 - planning the search in advance
- e (5) Database Descriptions
 - contents and use of data bases
- f (6) Beginning and Ending the Search
 - how to initiate your conversation with DIALOG and how to sign off when you're finished
- g (7) IIDA Facilities
 - how to use IIDA during your search

Strike the carriage return when you are ready to see the next frame.

The numbered frames (1) through (7) are mandatory for the user in exercise 3—he must see them all before going to further detail on any of the individual topics outlined. Following the eighth frame [frame (7) IIDA Facilities], the user is given the option of continuing with exercise 3 or of beginning a search in assistance mode.

You have seen the introductory frames of Exercise 3.

You now have two options:

- (1) to see more detail on any of the topics listed above, enter the two-digit frame number preceding the topic of interest.
- (2) To begin your search in Assistance Mode, enter '/done'. Enter a letter, any frame number, or /done.

If the user elects to continue with the exercise, he enters the number of any frame introduced by frames (1) through (7). The frames may be viewed in any order, and the user may follow a topic in as little or as much detail as he feels he requires. Each major topic is divided into subtopics which provide increasingly detailed instructions on the use of commands and techniques. When the user has exhausted one line of instruction to the most detailed level, he is instructed to enter a frame number to begin a new topic of instruction. During the exercise, the user is instructed to enter various commands, just as he was in exercise 1, and to view the system's response. When all frames have been seen, or when the user has seen all the information he thinks he needs, he exits exercise 3 by entering /DONE.

If the user chooses to begin searching in assistance mode after seeing the eight introductory frames, he may access the instructional material by using the /HELP command, by selecting HELP option #1, during his on-line search. The content of the frames is the same as what the user in exercise 3 sees; the only difference is that the user does not, in assistance mode, have the opportunity to practice the commands and techniques in simulated steps. Since the user in assistance mode is in the midst of a search when he accesses the HELP library, he is usually ready to return to the search as quickly as possible; use of the table of contents of exercise 3 and of the error messages encountered during the search, which indicate which help frame to access, allows the user to have near direct access to the necessary HELP frames. The user in assistance mode returns to the search from the HELP library by entering a DIALOG command.

Complete transcripts of exercises 1, 2, and 3 are included in (6).

6.3 Assistance Mode

Assistance mode is selected by the user when he is ready to perform an actual search. After logging in, the user selects assistance mode from the menu of exercises and modes. The automatic connection and login to DIALOG described in 6.2, is carried out, and the user is asked to enter the number of items he wants to retrieve. Unlike exercise 2, however, there is no introduction to assistance mode--from the user's view he is "on his own."

When logged in to DIALOG, the user performs his search in the usual manner, beginning with the BEGIN command. Diagnostic messages may be sent if errors are detected. These messages frequently contain reference to the HELP frame where correct usage is explained. The user may or may not choose to access the suggested information, but message syntax must be legal to be sent.

As long as the user is getting productive results and asks for no help, IIDA remains in the background until the user performs a TYPE command. Then, as in exercise 2, IIDA asks the user to rate relevance of citations printed (TYPED) out. A scale of 1 (not relevant) to 5 (highly relevant) is used. IIDA averages the relevance rating of sets of items viewed, and, over a sequence of TYPE commands, informs the user whether his assessment of the items retrieved is improving or declining. The user can modify his strategy to retrieve more relevant materials. If the relevance comment average declines over the typing of several sets, IIDA may offer assistance in correcting the problem, either at the user's initiation or through a strategic error message.

6.3.1 User-initiated HELP. There are three types of user-initiated HELP: reviews of the search from various perspectives, quick advice, and the help library. Either may be called for by the user any time he needs assistance.

By entering the command /HELP, the user receives a menu of HELP options:

- (1) the HELP library
- (2) command history
- (3) set history
- (4) history of records viewed during the search
- (5) history of errors made during the search
- (6) history of descriptors.

From this menu, he may select any option he feels will assist in his search. The histories (options 2-6) are designed to help the user keep track of the search in progress, and to allow him to see the search in perspective. For example, the history of descriptors used may prompt the user to bring a forgotten term into the search.

Once the user has seen the /HELP menu, he may use help directly by merely entering /H and the number of the HELP option desired. For example, having seen the menu once, a user might enter /H3 to review the sets created in his search.

A second HELP option is available through the use of another IIDA command, /QA. /QA stands for "quick advice," and provides the user with a brief recommendation from IIDA as to an approach to take. This advice is based on the histories maintained through the IIDA program, and lets the user know what approach might be appropriate following the most recent command entered. The QA option can also provide reassurance in that one of its messages tells the user that no advice is needed at the time.

The third user initiated HELP option is the library. It consists of the 80 instructional frames that comprise exercise 3. HELP is invoked by the user by entering the command /H1, or by selection of option 1 from the /HELP menu. When the user enters /H1, he receives the menu of seven broad topics of exercise 3, described in 6.2. At the end of the menu, the user is asked to select the topic of his choice by entering the number or letter of the topic selected. Since the frames of instruction are structured in a general-to-specific tree arrangement, the user may pursue the topic selected to whatever degree of detail necessary.

To exit the HELP library, the user simply enters a DIALOG command to return to the search. The user may pursue as many frames as needed while in HELP. The only difference between using HELP library while doing a search and using the frames as an instructional exercise is that when in a DIALOG search the user does not have the opportunity to practice using new commands and techniques--they are printed out as examples within the instructional frames.

6.3.2 IIDA-Initiated Assistance. Because IIDA maintains extensive histories on all aspects of the search in progress, the system is able to provide advice on strategic and syntactic errors.

One program describes syntactic error conditions and certain "hybrid" conditions which are neither syntactic nor strategic (for example, including a null set in a COMBINE command). Approximately 100 error messages are reconstructed by the program, which tell the user what kind of error he has made, what IIDA has "assumed," and finally the reason the command is illegal or invalid. The messages also inform the user of what to do to get further help. For example, a message might read;

```
D? type F8/5/1-4
80*** SYNTAX ERROR: Command assumed: 'type' Argument
assumed F8/5/1-4. The argument is not acceptable because
it does not begin with a set number. For help, enter
/H1.13.
```

The user may proceed with the search by correcting the error, or he may take the /HELP option offered and review the material in the library.

Strategic error analysis is less generalized. The content and context of each user message is analyzed and compared with previous search history. If strategic errors, or unproductive conditions, based on IIDA's rules, are detected, the program determines if a message is to be sent to the user. Every strategic error does not invoke a message, since some flexibility helps the user to experiment with different approaches, and too many "helpful" messages could irritate and confuse the novice searcher.

IIDA offers assistance on the following types of strategic errors:

- (1) creation of null sets
- (2) low relevance ratings or decreasing ratings
- (3) use of uninformative TYPE formats
- (4) creation but nonuse of sets
- (5) convergence and dwelling conditions
- (6) repetition of commands
- (7) problems with string length: excessive use of a single command consecutively

The user receives a message as to what occurred, why, and what to do to correct the condition or to get help. For example:

30\$Set examination: the following sets were given a relevance rating of .4 or more but were not typed with a full format when examined.

2

6

8

You may wish to resume this search to examine these sets in a full format.

The user is free to follow IIDA's advice or to ignore it. IIDA's role is to inform the user of the strategic condition, offer help, and to allow the user the freedom to use a strategy comfortable for him as a searcher. IIDA's help is available as the user needs it, but recognition is given to the fact that variations in searching logic and style exist, even among novices and casual users.

7. RELATIONSHIP OF IIDA TO OTHER SYSTEMS

While IIDA is essentially a new system, many of its features are related to philosophies, approaches, and techniques developed elsewhere. The purpose of this section is to trace the influences of concurrent and previous work on IIDA's development.

NLS Scholar (11) is an artificial intelligence based system designed to teach non-programmers to use the NLS editor, part of a modular system used as an aid in writing, editing, indexing, and publishing. Like IIDA, NLS Scholar combines instruction with actual use of a system which performs certain defined tasks. NLS Scholar's emphasis is on the natural language interface, and instructions, practice, and online assistance components are provided. The major difference between IIDA and NLS Scholar lies in the difference between online bibliographic searching, which is more structured than editing and the loose structure of the editing or writing tasks of NLS Scholar. IIDA can identify and assist in handling user errors rather specifically without the user needing to inquire of the system as to what to do next or how to correct a problem.

SOPHIE, a Sophisticated Instructional Environment (12), is a computer assisted instruction system which utilized artificial intelligence in the teaching of electronic circuit analysis and troubleshooting. Like NLS Scholar, SOPHIE provides instruction which is tailored to the individual; not only can the user progress at his own rate, but the systems provide advice to the user which is based on what he is doing, in the context of a real problem. Because the systems recognize that there are a variety of acceptable approaches to each task undertaken by the user, the user is encouraged to find the most suitable approach within the broad scope of "correct troubleshooting," "effective editing," or "productive online bibliographic searching."

SOPHIE differs from IIDA in several aspects. Most importantly, in SOPHIE there is always a correct solution to the users' problems. When the IIDA user performs his search in DIALOG, there is no single measure of performance since the search is structured and the relevance of the results

evaluated by the user himself. IIDA has, in a sense, extended the range of possible approaches available to the user because the DIALOG search is real in every sense, not a simulated situation. Because of the nature of the task involved, SOPHIE offers simulated circuit analysis and troubleshooting.

CONIT (Connector for Networked Information Transfer) is a product of the M.I.T. Electronic Systems Laboratory (13), and like IIDA was designed to make it possible for an end user of bibliographic information to perform online searching without the help of a trained intermediary. CONIT provides its own command language which the end user utilizes to search several data bases supplied by more than one commercial vendor. IIDA, on the other hand, teaches DIALOG and offers the user the limited choice of four files--ERIC, NTIS, COMPENDEX, and ONTAP ERIC. CONIT translates its command language into that of the selected data base vendor's language, enabling the user to learn only one language for use with multiple services. On the other hand, IIDA users learn DIALOG's commands. The commands, if valid, are sent by IIDA directly to DIALOG. Therefore there is no translation from IIDA's language to DIALOG's--they are the same with the exception of a few commands which invoke the IIDA help program and which allow the user to change from one IIDA mode or exercise to another, or to exit the IIDA system altogether.

A second major difference between the systems is with regard to their assistance programs. CONIT and IIDA both offer extensive online assistance to the user with a search in progress. CONIT's assistance is more general in nature than IIDA's. The IIDA help programs evaluate the user's errors in syntax or strategy in the context of the specific search in progress. IIDA maintains an extensive history of each search which is analyzed when an error is made or when the user asks for advice. The help is rendered on the basis of the user's errors as well as strategies and techniques assumed to lead to productive searching by casual or novice users.

CONIT assists the user in selecting the appropriate data base for his search. IIDA, on the other hand, gives a more limited choice of data bases and only explains them to the user in exercise 3.

Another system which predates IIDA is the University of Pittsburgh's CAI TRAINER (14). This system has some similarities to IIDA's instructional mode. TRAINER, like IIDA, teaches online searching and has a "practice" mode, but the important difference is in the form of practice. In IIDA, the user is connected to the DIALOG information retrieval system in the second exercise and performs an actual DIALOG search. TRAINER offers simulated searching from three files.

While the CAI contents bear some similarities, these are as they pertain to actual searching. IIDA teaches the user several commands [HELP, /QA (Quick Advice), etc.] peculiar to IIDA, while TRAINER instructs in terminal use, telecommunications protocol, identification, access procedures, and even offers practice in logging in. Since IIDA handles the login procedures for DIALOG, there is no reason to instruct the user in that process in an extensive way.

TRAINER, like IIDA, is designed for the casual users; however, it provides no interface with the actual search systems and was designed specifically to perform the training function.

The work of both Penniman (15) and Standera (16) influenced the approach which IIDA takes in teaching the search process. Penniman categorized search commands into four groups: index search, logic formulation, document display, and other administrative commands. Standera's observations led to the identification of a slightly different classification of commands: start/stop; executive (logic and display commands); supportive (index search, set history); informative (procedural or data base information); and auxiliary (offline print, copy ordering, etc.).

IIDA, for instructional purposes, has used Penniman's categorization, slightly modified by Standera's:

- (1) Index search (EXPAND; SELECT w/single term)
- (2) Logic formation (SELECT w/full text capability, COMBINE, etc.)
- (3) Record display (TYPE)
- (4) Procedural (BEGIN, LOGOFF, FILE)
- (5) Diagnostic (HELP, EXPLAIN, etc.)

The first three of these categories also define the order of proceeding with a search that is taught by IIDA tutorial exercises. Once doing their own search (e.g., exercise 2), the users may modify the order to suit personal style. One concept that is introduced in IIDA is that the users are explicitly introduced to the notion of recycling through the index search and logic formation commands should the record display reveal that the set created on the first cycle needs to be refined or re-defined.

IIDA's approach in teaching only the seven basic command (BEGIN, SELECT, EXPAND, PAGE, COMBINE, TYPE, LOGOFF) and then encouraging users to practice "real" searching, is in keeping with Standera's view that most searchers confine themselves to very few commands in the performance of an online bibliographic search. Exercise 1 of IIDA was designed to introduce online searching to the user and to get him started. Exercise 3, largely optional as an instructional program, provides advanced commands and techniques.

8. EVALUATION

In the evaluation of IIDA, the concern has been both with formative and summative evaluation. In formative evaluation, the focus has been upon monitoring system development and with providing feedback and information leading to the refinement and further development of the system. For example, a number of the diagnostic rules in the assistance mode require specification of a threshold value. Initially these values were set by intuition or arbitrary choice. However, the use of the system has enabled revision of some of the values towards more appropriate levels.

In the summative evaluation of IIDA the concern has been with assessment of the impact and effectiveness of the IIDA system and with the degree to which the objectives of the project have been met. In the discussion which follows the three major phases of IIDA evaluation are summarized. The first- and second-stage evaluation are described more fully in (17), and a description of the details of the third-stage appears in (18).

8.1 First-Stage Evaluation

Although labeled first-stage evaluation, the kind of formative evaluations described here were to some extent conducted continuously throughout the entire development of IIDA.

8.1.1 Project Staff Evaluation. Once exercises 1 and 2 had been made operational, and on a continuing basis thereafter, the various exercises were subject to review for improvement and modification by all members of the project staff. In addition, all members of the staff spent time interacting with IIDA as users in order to look for flaws or ways to improve the operation of the system.

8.1.2 Computer Science Majors. Another group which worked with the system during this early testing were three undergraduate computer science majors who acted as users and who were challenged to find the problems. The emphasis in this testing was upon exercise 2 which not only stands as part of IIDA but which also, in a sense, provided a nucleus which was expanded into

the assistance mode. All three of the students were able to search successfully using IIDA and ran into very few problems in doing a search. Those programming and technical flaws discovered at this stage were subsequently corrected.

8.1.3 "Real" Searches. With exercise 2 fully operational, a number of searches done by real searchers were re-done through this exercise in order to look at the responses of the system and the diagnostics to "real" searches. The seventy-two searches involved were taken from a set collected by Fenichel (24) in a study on search process assessment. Every member of the project staff regardless of their role on the project duplicated a minimum of four searches through exercise 2. Thus, all members of the project staff were involved in looking for flaws that needed to be corrected. In addition, all of the staff members were able to gain first-hand experience with how IIDA would have treated the user who had done the search.

While no major substantive changes were immediately made in the system as a result of this exercise, it was of particular benefit in insuring that the entire staff had a coherent and complete feel for the project as a whole rather than for just that sub-component upon which each happened to be working at the time. Furthermore, it was also of benefit in helping to provide a basis for later decisions about various questions which arose about such issues as how and what to implement in the way of messages from IIDA, etc. Finally, it provided various staff members with an important background context against which to weigh various user comments collected at the time of use or during post-use interviews and discussions.

8.1.4 Library and Information Science Faculty and Graduate Students. Three graduate students and two faculty members of the Drexel University School of Library and Information Science also went through the entire set of IIDA exercises (exercises 1 through 3) before testing was begun with novice users. Once again these tests were useful in that they uncovered programming errors which had not yet been discovered and corrected. All of these users were experienced with online bibliographic searching and generally liked the IIDA programs. However, they were not completely successful in

detecting problems with the content of the instructional programs from the novice user's point of view. In later testing, undergraduate engineering students with no library training or bibliographic searching experience found difficulty both in comprehending some aspects of the material in exercise 1, and in absorbing the bulk of material in exercise 3. Apparently it was difficult for the library school test participants, as for the staff, given their familiarity with online searching, to appreciate the way a complete novice would respond to the instructional material.

8.2 Second-Stage Evaluation

In the second-stage of the process of IIDA evaluation, there were two studies conducted which provided information on both formative and summative evaluation. Each of these two studies was addressed to a different kind of question. Given the structure of the total IIDA system, it is possible to look at the effects of IIDA when the system operates only as an assistant. When dealing with this question, it is assumed that the user has previously had a reasonable amount of search training and engages IIDA only through the assistance mode. The second kind of question one can ask has to do with the effectiveness of the IIDA exercises in teaching new users to do bibliographic information retrieval. When dealing with this issue, it is assumed that the user has had no previous direct experience with searching and utilizes the capacities of IIDA as both instructor and assistant.

8.2.1 IIDA as Assistant. Each year the School of Library and Information Science at Drexel University admits a number of new graduate students. When these students are admitted, they are required to register for a course entitled, "Fundamentals of Library and Information Science." One of the components of this course is a block of instruction in computer based bibliographic searching. This block of instruction, roughly totaling thirteen hours, includes both classroom lectures and hands-on laboratory experience in searching. The Fundamentals students were recommended as a group for study not only by their accessibility, but also because they knew how to search at a novice level, were fairly homogeneous in training and experience, and could be expected to experience some problems with their searches which would trigger the diagnostics.

From a summer session class of twenty-six students, there were twenty-two volunteers. Of these twenty-two, seventeen actually began and completed the study. Each student was asked to conduct two searches in the same order. Randomly, half of the users were assigned to conduct the two searches with IIDA assistance while the other half were assigned to do the searches without assistance. In both cases the searching was done through IIDA so that the search records were kept automatically, but with the no-IIDA group the interactive messages were suppressed so that the users were not given the IIDA feedback. Five sets of search records were lost as the result of system difficulties which did not appear to be statistically related to the user's group membership. This loss left five users in the no-IIDA group and seven users in the IIDA group.

Comparisons of the two groups revealed that they did not differ statistically from each other in terms of the frequencies with which the various categories of diagnostics were invoked during the process of searching. The data used were those from the second search only. The only differences between the two groups found in examination of the attitude measures on the post-search questionnaires showed up on two questions. While the IIDA assisted group showed a higher level of agreement with the statement that the assistance mode of IIDA had helped in searching more effectively, it was the no-IIDA group which indicated the highest degree of agreement with the statement that the IIDA searching had been enjoyable.

The users described in this study were all trained but inexperienced searchers, some of whom did searches with IIDA assistance. In general the reactions of those who did their searches with IIDA were positive in that they felt the system had provided them with valuable or worthwhile assistance. While there did not appear to be any effect of IIDA assistance upon the frequency with which the diagnostics were triggered during the search, the number of searches in each group was relatively small and so there may have been effects which were not detected. It was reassuring, however, to find that the direction of differences would have favored the IIDA group if the results had been significant. This would make it reasonable to assume that even if IIDA assistance did not measurably improve the searcher's performance, it also did not seem to impair it.

8.2.2 IIDA as Instructor. Turning to the issue of how well IIDA is able to perform the service of enabling novice users to do a successful search, the concern is basically with a user group which has had no previous experience, either direct or instructional, with computerized information retrieval. One such available group of users was found among Drexel undergraduates enrolled in courses in technical writing. The study originally planned for this group was abandoned as the result of unanticipated hardware problems. However, a number of students were provided with IIDA training and search assistance. Thus, the study described below was descriptive rather than experimental in nature.

In all, thirty-five undergraduates, mostly Junior and Senior engineering majors, were recruited from two summer session sections of technical writing. Student participation in the IIDA training was strongly encouraged by the instructors, but participation was not a class requirement. The students were encouraged to use the opportunities for searching to compile bibliographies for their term paper and other writing assignments in the course. These users were initially scheduled to do exercises 1 and 2 in one session and exercise 3 and a search of their own choice during a second session. Various kinds of difficulties resulted in many of the students having to return for one or more additional sessions.

Of the original thirty-five students who began, thirteen dropped out or did not finish the three exercises and searching for one reason or another. Based upon user comments, instructor feedback, and a post-training debriefing conducted with one of the technical writing classes as a group, the high dropout rate was attributable to two major factors. The first of these was the length and amount of material covered in exercise 3 as it was structured for these users. The second factor contributing to the high dropout rate was a relatively high frequency of system difficulties external to the IIDA programs. While occasional hardware problems were encountered with the computer that housed IIDA, more often there were problems with DIALOG going down. However, the single most frequent set of problems arose with telecommunication network difficulties which resulted in several participants being required to schedule more than two sessions to complete the course of training and searching. Some users simply refused, others just disappeared. There were also a few who dropped the writing course and dropped IIDA as well.

Although this study provided no comparative data on the diagnostics for different user groups, it did result in an intensive examination of the operation of the machine scoring procedures. Because of the considerable online interference encountered during much of the study, some "errors" reported by the computer were not caused by the searchers. The search transcripts were examined in detail by the IIDA staff and the machine reported errors were analyzed to determine which were in fact a result of a user difficulty. Those faults or errors which resulted from a malfunctioning of the IIDA programs were brought to the attention of the system programmer so that future problems could be minimized or avoided.

One of the questions on the post-training questionnaire asked the students to report the percentage of items retrieved in the search that were: (a) Very Useful, (b) Useful, and (c) Useless. Since the ultimate criterion for the value of the information retrieved lies in the judgment of the user, this was felt to be a particularly important index to the success of the system. The first two categories were combined into a single percentage useful score, with an average of 60% of the references retrieved being judged either useful or very useful. Not surprisingly, there was some variability in this score, with extremes ranging from 0% to 100%. It was also the case that the users' judgments of the percentages of useful items retrieved were significantly correlated with some of the other variables investigated. Percentage useful was negatively correlated with the number of syntax errors made and was positively correlated with scores on various questions designed to assess the users' attitudes towards different aspects of IIDA and IIDA-assisted searching. This pattern is suggestive in that it raises the possibility that problems with syntax errors influenced the degree to which information was successfully retrieved. It further suggests the possibility that the users' evaluations of the search system, when doing their own searching, may be influenced by the degree to which useful information is retrieved.

In terms of their detailed comments about the system, almost all of the users in this group found positive things to say. They also found negative things to say. In addition, these users suggested a number of detailed kinds of ideas about things they did not find in IIDA that they

thought should be included, and they were able to provide detailed feedback about a number of instances in which they felt that IIDA had done or said the wrong thing. Fewer than one-third of these users felt that they would be able to do searching on their own without IIDA assistance.

8.2.3 Discussion. It seems, from the information presented so far, that by the end of the second stage of testing the IIDA system was in good enough shape to be able to provide the type of training and assistance necessary to enable novice users (at least some novice users) to do online bibliographic searching. Certainly there is no reason to expect that the technical writing students would have been able to sit down at a terminal with no prior instruction and no online assistance and be able to search as well as they did. Thus, one of the major goals of the project had been accomplished, i.e., the development of such a system in a computer-based interactive framework. It was also clear, however, that a number of substantive problems remained in that while the average percentage of useful items retrieved by the technical writing user group was 60%, there were several users who were dissatisfied with the system or were unable (or, possibly, unwilling) to retrieve any reference which they felt to be useful. Had the evaluation of IIDA ended with the work reported to this point, a reasonable summation of the results of the project would have been, "It seems to work, but major improvements remain to be made."

The summer studies were, however, pilot testing for subsequent field experiments to be reported on below. Several lessons were learned from the use of IIDA by the various user groups which led to major benefits in the conduct of the field studies. One obvious benefit from the pilot testing lay simply in the use of the instructional and assistance programs with real users searching real problems. This led to the discovery of as yet undiscovered technical and programming problems. In addition, the testing, along with the network transmission and other technical problems encountered during the summer, motivated a detailed search by search comparison between the search transcripts produced by users and the machine kept records of search activity. The results of this comparison led to improvements in the operation of the automatic record keeping functions of the programs.

Some additional benefits which accrued from the summer pilot testing involved the questionnaires and the research assistants. The extensive feedback from the technical writing students also included commentary about the questionnaires used in the study. This feedback, and examination of the data actually collected on the questionnaires, led to modifications in, and a considerable shortening of, the questionnaires. The research assistants involved in the project gained invaluable experience from the pilot testing in dealing with the problems of working with the system, in working with the users being trained, in coping with the problems of scheduling users, and in conforming to the needs of a research plan. The assistants were also able to develop a number of important insights into the operation of the system and the problems of the users.

Also as a result of testing experiences with the various user groups, especially with the technical writing students, modifications of the instructional exercises were introduced to either clarify the information or to make the exercise more palatable. The types of changes made to exercise 1 were primarily those of clarification. For example, at first some students expected to retrieve actual facts about their topic rather than references. Others did not seem initially to realize that the commands in exercise 1 were to be learned for future use. Still others displayed a conceptual misunderstanding. At the time of the summer testing, exercise 1 employed an example search on Library Automation as a format for introducing the various commands and illustrating their use. At one point in the search, IIDA asked the user to enter EXPAND LIBRARY. A few of the users were not entirely clear, however, about how to use EXPAND, as illustrated by the fact that they subsequently thought they should enter EXPAND LIBRARY no matter what the term was that was to be expanded. All of these problems were spotted early in the testing and appropriate changes to exercise 1 were introduced.

After the completion of the training of the technical writing students there was also an extensive revision of the structure of exercise 3. In its original format, this exercise consisted of eight frames with extensive discussion and detailed elaboration of the material in each, as a form of advanced training. Since each user was required to go through all of the material in the exercise, the total time required to complete it averaged about forty minutes. The exercise was changed in that the structure of the

program was modified to require the user to be exposed to only the introductory descriptions of the various advanced training materials. Thus the user is now required to take a reference walk through exercise 3 in order to become familiar with the contents of the advanced training material. Then the user has the option either of learning more in exercise 3, on a self-selected advanced study basis, or of going on to the assistance mode. Once in the assistance mode the user has the option of returning to the contents of exercise 3, in the form of the help library, whenever necessary.

One important point which was convincingly demonstrated by the second-stage evaluation of IIDA is that the kind of pilot testing described here is an indispensable part of the development of any system as large and complex, and as user-oriented as IIDA. Because of their closeness to the material, the system designers are, at times, not the best judges of what material should be viewed by, explained to, or simply available to the user. It is very easy to let the necessary concern with the problems of technical development outweigh the seemingly more mundane problems of user compatibility. There is, however, in a user-oriented system, little to commend the most technically brilliant programming accomplishment or design feature if it is beyond the capability of the user to take advantage of it.

8.3 Third-Stage Evaluation

The third-stage of IIDA evaluation following closely upon the completion of the system revisions suggested by the results of the second-stage evaluations. The studies described here were conducted with the kinds of users, and in the environment, for which the system was intended. During the fall of 1979 and the winter of 1979-1980, two field experiments were conducted with research engineers and research chemists at two different Exxon Research and Engineering Company sites in New Jersey. In one of these studies--the baseline study--the performance and reactions of IIDA trained and assisted searchers were compared with those of end users who had had searches done for them by the professional intermediaries at the Information Center on site. In the second study--the training method study--the performance and reactions of IIDA trained and assisted searchers were compared with those of

searchers who were given more conventional classroom-type training and then assisted in searching by IIDA. Thus, in one case the focus was upon the adequacy of IIDA as a total system for enabling the user to retrieve information, and in the other the focus was upon the IIDA training materials as a way of providing online search training.

8.3.1 The Baseline Study. The baseline study was conducted at the Exxon Research and Engineering Company facility at Florham Park, New Jersey, in the fall of 1979. The study design called for collecting data on the searches performed by twenty-five searchers who were trained and assisted by IIDA. In addition, twenty-five searches were to be done by the information retrieval staff on site.

The design of the study was a simple treatment and control group design with half of the participants being randomly assigned to each group. The fifty participants were randomly selected from a list of almost 150 volunteers who had been recruited by a mailing which described the opportunity to be involved in IIDA bibliographic search training and offered them the opportunity to participate. Those participants assigned to the IIDA group were trained to search using the IIDA programs and then did two searches on subjects of their own choosing. The other participants, in the intermediated group, submitted the next search topic arising from their regular work to the information center intermediaries. These searches were then conducted by the intermediaries through IIDA, but with the IIDA diagnostic messages being suppressed. All searches were done in Compendex.

As the result of an IIDA program system difficulty some of the search records for the intermediated searches were not preserved and printed out for later use. Of the topics actually submitted, IIDA diagnostic data were available on only sixteen of the searches. Consequently, the data that were available on all of the intermediated searches, e.g., the order in which the searches were done and the post-search questionnaire questions, were split into two groups. One group consisted of those participants where the diagnostic data had been lost, the other the group where the diagnostic data had been preserved. Statistical comparisons using the conservative alpha level of .25 revealed no significant differences between these two groups so it was assumed that the loss of search transcripts was effectively random.

Comparison of the participants in the IIDA trained and intermediated groups on several pre-search measures revealed no significant differences between the groups, indicating that the randomization had had the desired effect. These two groups also did not differ from each other on several post-search measures of their reactions to the searches. For example, in terms of judgments of the percentage of useful items retrieved in the searches, the difference was not statistically significant, with the IIDA trained group indicating an average of 52.5% of the references retrieved were useful, while the intermediated search participants indicated that an average of 49.3% of the references retrieved were useful. Thus, the IIDA trained and assisted users were able to produce satisfactory searches. It was also found that there were no significant differences between the two sets of searches in terms of the number of IIDA detected errors or faults in the searching behavior of the professionals and in the searching behavior of the IIDA assisted users. Although comparable information was not available for both groups of users, the responses of the IIDA trained and assisted users to open-ended evaluation questions seemed to clearly indicate an overall positive response to the system. This is not to say, however, that there were still not things that the users did not like. But an overall improvement in the system from second- to third-stage evaluation is clearly suggested by the fact that 88% of the IIDA trained and assisted users were willing to recommend the online search system, including IIDA, to their friends. In addition, 88% of these users felt able to search on their own. This represents a considerable change from the response of the technical writing students involved in working with IIDA in the second-stage evaluation.

In light of the intent of this study, i.e., to provide a set of diagnostic benchmark criteria against which to assess the performance of the IIDA trained and assisted searchers, it was surprising to discover a lack of significant differences between the two groups of searches. A significant difference on one or more of the diagnostics would have pointed toward a deficiency in the IIDA training or in the usefulness of the diagnostic messages during IIDA assisted searching. The finding of no significant differences also poses a potential problem in that it is not clear whether this means that the IIDA diagnostics worked well or that they are not sufficiently sensitive to the type of "errors" detected.

In looking at the lack of differences between the two sets of searches, there are some circumstances which suggest that the professionals may have been somewhat handicapped relative to their habitual mode of searching. For example, the Exxon professional searchers are used to working with 1200 baud terminals. With these terminals, more online printing is acceptable than with the 300 baud terminals used for IIDA searching. Hence, the professional staff was accustomed to doing a great deal of online printing, often exceeding the limit allowed for IIDA users working with the slower terminal. Also, IIDA's design was fixed just before Lockheed announced the new super select command (25). Hence, this command was not included in the IIDA training materials and its syntax was not recognized by IIDA's parser, and would trigger a diagnostic error. Consequently, although it is not possible to assign numeric values, there is reason to believe that the error-fault rate of the professional searchers might have been higher than normal.

In addition, the professional intermediaries at Florham Park were working under unusual time constraints due to severe scheduling problems. These time constraints made it difficult for professionals to search in their "normal" manner. The scheduling of the intermediaries' searches on IIDA became such a problem that, part way through the experiment, these searches were begun on IIDA, but were then saved, executed, and printed on Exxon's 1200 baud terminals.

Another factor to be considered in evaluating the results of this experiment is the possible difference in the nature of the searches conducted by IIDA users and the professional intermediaries. The professional searchers performed comprehensive searches on a pre-defined topic. It was not required that engineers have a pre-defined search topic or that they do a comprehensive search. There is considerable doubt that the engineers and intermediaries did the same kind of searches. Nonetheless, it is certainly true that the IIDA searchers performed respectably well and were satisfied with their search results.

One reason for arguing that the training and assistance routines worked as intended lies in the fact that the end user evaluation of the utility of the information retrieved in the searches did not differ significantly between the two groups. IIDA users also did not differ

significantly from those participants who had had intermediated searches done for them in terms either of their degree of satisfaction with the search system used or of their willingness to recommend the search system to their friends.

8.3.2 The Training Method Study. The second major test of IIDA took place at the Exxon Research and Engineering Company facility in Linden, New Jersey, during the winter months of 1979-1980. This study involved a comparison of the searches done by IIDA trained and assisted searchers with those done by a group of searchers who were also assisted by IIDA but who had been trained in a two-hour classroom training session. The intent of this study was to test out the instructional procedures and materials involved in IIDA training against a more frequently used and more conventional training method.

The design of the study was a simple two treatment experimental design with half of the participants being assigned randomly to each group. As in the baseline study, the fifty participants were randomly selected from a list of almost 150 volunteers who had been recruited by a mailing which described the opportunity to be involved in bibliographic search training and offered them the opportunity to participate. Those participants assigned to the IIDA trained group were trained to search using the IIDA programs and then did two searches on subjects of their own choosing. The other participants, in the conventionally trained group, did two searches of their own choosing, with IIDA assistance, after having been trained at one of four training sessions organized and taught by one of the Information Center professionals. Although each session was conducted by a different professional, the same instructional materials and handouts were used in each. The experimental design did not allow for online practice time, but some participants saw an online demonstration. All searches were done in Compendex.

Comparisons of the two groups on several pre-search measures revealed only one significant difference between the two groups. This difference, in the average number of computer languages known by the users in the two groups, with the IIDA group having a higher average, did not seem to be a very strong one, however, in that further investigation indicated that the number of users who knew no languages at all was not significantly different between the two

groups and that those users who knew one or more computer languages did not differ between the two groups in terms of the mean number of languages known. Furthermore, the number of languages known turned out not to be correlated with any other variable investigated in the study except the individual's self-rating of computer skills, and the two groups did not differ significantly on this measure.

The two groups also did not differ from each other on several post-search measures of their reactions to the searches and the search assistance system. For example, in terms of the judgments of the percentage of useful items retrieved in the searches, the conventionally trained users indicated that 62.9% of the references were useful and the IIDA trained users indicated that, on the average, 46.6% of the references retrieved in their searches were useful. This difference was not statistically significant. Where differences did exist, they were related to characteristics of the search assistance system rather than the search results. Those users who were conventionally trained seemed to be more likely than the IIDA trained searchers to agree that the instructions in the search system were easy to follow and that the system was easier to use than had been expected. In addition, the conventionally trained group expected to encounter more difficulty with the system than was in fact the case. Interestingly enough, these differences reflect favorably on the IIDA assistance programs in that experience with the IIDA training exercises is clearly not necessary for the individual to be able to make use of the assistance mode.

It was also found that there were no significant differences between the two sets of searches in terms of the number of IIDA detected errors or faults in the searching behavior of the two groups. Finally, although statistical analyses were not conducted, the responses of the two groups of searchers to open-ended evaluation questions seemed to clearly indicate two things. The first is that IIDA is not a finished product without fault. The questions designed to elicit negative comments from the users were clearly able to do so. The second is that overall most of the users seemed to like learning to search, either with or without IIDA, and they seemed positive about the IIDA assistance they received. It is also interesting to observe that the users did not draw a clear distinction between the characteristics of IIDA and those of DIALOG or the telecommunications. This is not surprising

since IIDA was designed to be as unobtrusive as possible during searching. However, system designers should be aware of the fact that users generally tend to evaluate the system as a whole and that the newly designed component, such as IIDA, may get the credit or the blame for characteristics of the other parts of the system.

The finding of no significant differences on the diagnostic measures could pose a problem for interpretation of the results were it not for the fact that both groups were able to retrieve a significant percentage of useful references during their searches. Presumably this represents something which neither group would have been able to accomplish if simply turned loose with a terminal but without having any training or assistance of any kind. Furthermore, the two groups did not differ significantly in their estimates of the percentage of useful references retrieved. In addition, a total of 84% of the participants in each of the groups were of the opinion that they would be able to search on their own, and even more were willing to recommend the system to their friends, with 92% of the conventionally trained group and 88% of the IIDA trained group, checking this question in the affirmative.

This pattern of results argues strongly for the idea that IIDA training, as it is presently structured, represents a viable alternative to the type of conventional training with which it was compared. One reasonable guess as to the reason for the pattern of results reported here is that while the human instructor may well in fact have been more flexible and responsive during training in assisting the student and in answering questions, the design of IIDA does, as intended, enable the user to discover where and how to get the information needed to answer the questions for himself. IIDA provides an avenue of access to online searching for individuals who could not or would not do a conventional training course and who still wanted personal rather than intermediated access to a data base.

8.4 General Discussion

A major goal of this project has been to provide a method for allowing direct user access to bibliographic searching. Thus, the attempt has been to develop a set of computer software packages which can provide online assistance to occasional users of information retrieval systems. This collection of programs is also intended to be able to provide instruction, if

needed, in the commands used in searching and in search strategy. When originally conceived, the expected utility of IIDA lay in the area of what might be called "problem solving searches." These are searches where the end user of the information does not know exactly what the characteristics are of the desired set of references until they have actually been found. Consequently, it is very difficult for the end user to describe the problem to an intermediary. There is no reason, however, why the IIDA user could not and should not make use of the system for all kinds of searches, if desired.

The primary intended IIDA user has been the working scientist or engineer who may need access to the data base only a few times a year, and consequently is not interested in training oriented toward those who become professional intermediaries. This person is assumed to be comfortable using computers, but not necessarily trained in their use. In addition, it is assumed that this user is a serious, well-intentioned searcher who is trying to use the system to solve a problem. The IIDA software and diagnostic procedures were created to help remove the barriers to access for these users. Minor modifications of the system, however, could make it available to a much wider audience.

Given the nature of IIDA, it is not possible to completely separate the performance of IIDA from the performance of IIDA users. For summative evaluation purposes, the users of primary interest are those described in the third-stage of IIDA evaluation studies. Looking first at the baseline study, the average rated satisfaction of the IIDA users and the participants who had intermediated searching done did not differ. In addition, the majority of the users in both groups were pleased enough with their results and experience that they were willing to recommend the system to their friends.

In the judgment by the end user of the percentage of useful references retrieved in the searches, there was no significant difference between the results obtained by the professional searcher and those obtained by the user performing his own search. It was also found that there were no significant differences in the number of IIDA detected errors or faults between the IIDA trained and assisted searchers and the professional searchers.

Similarly, the two user groups which differed in the method of training prior to doing IIDA assisted searching had no appreciable differences either on the diagnostic measures or in the percentage of useful references retrieved. In addition, the members of both of these groups did not differ significantly from each other on several measures of the reactions to the search system, with, for example, most of the participants feeling they would recommend the system to their friends. Where the two groups did differ, however, was in the evaluation of the system instructions and the ease of use of the system. In both cases the conventionally trained users indicated a higher degree of agreement than did the IIDA trained users. That is, they were more likely to feel that the instructions were easy to follow and more likely to indicate that the system was easier to use than they had expected.

The finding of so few significant differences, particularly on the diagnostic measures came as somewhat of a surprise. In a case where no significant differences exist, the situation is always troublesome in that such a finding could occur because the two groups did not differ, or because the measures chosen were irrelevant. This latter explanation, however, seems to be less reasonable than the idea that the system works as it was designed to work. One reason for arguing that the training and assistance routines worked as intended lies in the fact that in the baseline study the end user evaluation of the utility of the information retrieved in the searches did not differ significantly between the two groups. This means that a group of individuals who had never before done online searching were able, with IIDA training and assistance, to do searches which produced satisfactory results containing useful information. A second reason for not assuming that the diagnostics are irrelevant as indices of searching behavior lies in the fact that the diagnostics were all empirically developed. That is, they were all designed to index and deal with problems encountered by searchers which have been either observed by the designers, reported in the literature by others, or both.

However, recognizing that the conclusions about the effectiveness of the diagnostics are not as clear and unambiguous as might be desirable, there are some additional directions for future research which ought to be followed. The first of these has to do with the evaluation of the diagnostics. The overall requirements for evaluation of the project as a

whole, as well as the available resources, dictated that some studies have a higher priority than others. This led to a concentration on the evaluation of the IIDA system as a system rather than a more direct focus on the diagnostic component of the system. A future evaluation devoted solely to the question of the performance of the diagnostic system, with and without various kinds of training in advance, would be both useful and desirable.

Another line of investigation dealing with the diagnostics which could be followed has to do with the possibility of adaptation to user skill level. The diagnostics were designed for use in a limited context, the training and assistance of the kind of novice user described earlier and in the user studies reported in the third-stage evaluation. There was some indication in the experiences of the professional searchers in the baseline study that when some of the diagnostics are employed with highly experienced searchers, they may not be the most appropriate procedures. There may have been times when diagnostics were triggered by relatively sophisticated searcher behavior which is appropriate in one context, but not in the situations with which IIDA was designed to cope. Thus, there is reason to believe that some of the diagnostics may not be equally useful or desirable for all user skill levels. Consequently, the diagnostics should be tested out more thoroughly with persons of differing skill levels. In addition, it would also be desirable to test different variations of the diagnostics. In particular it would be of interest to determine whether or not it is possible, by varying the thresholds in the existing set of diagnostics, as a function of the prior performance of the user, to get the diagnostics to perform adequately with individuals of different skill levels. That is, can they be made adaptive? One possibility is discussed briefly in section 9.

A third direction for future research has to do with the type of IIDA user. Although the original target user group for IIDA consisted of technically trained individuals interested in a particular class of search problems, there now seems to be no reason not to attempt to extend IIDA. The technically or scientifically trained user may be only one of several kinds of users who would find IIDA attractive and useful. In particular, it seems desirable to determine whether or not a system such as IIDA can be used to provide direct access to data bases for a wide variety of possible end users interested in a wide variety of search problems. In fact, it may well be that

IIDA, or an IIDA-like system, is a viable method of introducing the computer and online searching to users with little or no background or experience with computers.

The fourth recommendation for future research follows from one of the limitations of the studies described above. These studies, and many other studies on searcher behavior, tend to be flawed by the fact that there is a relatively short amount of time between when the participants in the testing are first exposed to the system and when the evaluation of their performance, or of the system performance, takes place. In addition, there seems to have been little or no testing of information system users at several points over a long period of time in the investigation of development or change in behavior over time. In the studies described above, the volunteer subjects generally tended to want to do the whole set of exercises and then do their searching in a relatively short time. It seems particularly desirable that a long range study be done, over a period of a year or so, in which the focus is upon how different people adapt to a new system, how quickly they adapt, how their behavior changes over time, and how it changes as the result of multiple search experiences.

In conclusion, it seems that a new idea has been fairly tested in the very environment for which the concept was intended and has come off quite well. Indeed, one of the important characteristics of the two third-stage evaluation studies is that there appeared to be no differences among the results produced by the various user groups when there was every reason to expect in advance that there would be a number of differences. While some aspects of these results are not entirely conclusive, they are supportive of the idea that the IIDA diagnostic procedures did indeed adequately measure important aspects of user performance. What is more certain, however, is that the IIDA system represents a way of training and assisting novice users in doing their own data base searching. Furthermore, IIDA clearly represents a viable alternative route to gaining direct data base access for those end users who cannot or will not do more conventional forms of search training.

9. SEARCH CHARACTERISTICS

Near the end of the project, a brief study was undertaken to determine if there were useful patterns of searcher behavior in data descriptive of frequency of use of various command types or of the probability of transition from one command type to another. Frequency of use data appears to be descriptive of rather broadly based stylistic behavior, rather than of specific errors or instances of poor usage. Hence, while we anticipate that the overall frequency data may prove useful in IIDA-like systems, we do not suggest that it is a replacement for the types of diagnostic procedures employed in our main study. Rather, we see the investigation of frequencies of use and transitional probabilities as a step beyond the level of analysis incorporated in the diagnostics. The basic concept for this kind of analysis in this context was set forth by Penniman (19) and the results summarized here were reported by Chapman (20). While the results presented here are far from conclusive, they suggest new avenues of research which might lead to more sophisticated intermediary systems, better able to diagnose the nuances of user performance and hence better able to respond to a particular level of behavior.

9.1 A Search as a Markov Process

Penniman described a search as a Markov chain of command states, where a state is the condition of having issued a command of a particular type. Markov chains can be analyzed at levels zero through any arbitrary number, n. A level indicates the number of states preceding the one being considered: level zero gives the raw frequency of occurrence of a state, level 1 gives the frequencies of occurrence of transitions from one state to another, with no intervening states; level 2 gives the frequencies of occurrences of transitions from state s_1 to s_2 to s_3 , etc. Thus, level zero measures overall frequency of occurrence of each state, level one measures frequency of going from any state to any other state, level 2 the frequency of going from any state to any other via one intervening state, etc.

Chapman applied Markovian analysis both to individual state occurrences and to strings, treating a sequence of commands of type t as a

single entity, a string of type t. Data used in her analyses consisted of the search transcripts of the IIDA evaluation studies involving (1) Drexel library science graduate students, (2) Exxon engineers, and (3) Exxon scientists. In each case, the subjects were divided into two groups and comparisons were made between them. In each case significant differences were found between the two groups.

The library science group were trained conventionally in the classroom. Then, some of the participants performed searches with, and some without, IIDA assistance. Those participants using IIDA assistance used significantly more dictionary search (expand) and significantly fewer type commands than the non-IIDA participants. State transition data, at various levels, were reflective of this basic fact. All significant differences in transition frequencies involved those two command types. String type transition analyses showed the same pattern as state transitions--significant differences in the use of expand and type commands.

A second group consisted of engineers at Exxon Research and Engineering Company. Half of them were trained by IIDA and then performed a search using IIDA assistance. Half took their search topics to professional searchers who performed the searches for them. Comparisons were made between the IIDA assisted users and the professionals. In this comparison there were significant differences in the zero order analysis for such commands as limit and advanced usages of select (more by the professionals) and expand and type (more use by the IIDA users). It should be noted that an analysis of diagnostics between these two groups showed little difference, while the command frequency analysis shows several differences.

The third group consisted of scientists at Exxon, half of whom were trained by IIDA and half by conventional means. Then, both sets of participants searched using IIDA assistance. These participants showed a significant difference in the use of advanced select commands, with the IIDA trained searchers having the lower frequency. This difference is probably attributable to differing emphases in the training programs and suggests that novice users are highly receptive to the searching style presented in the instructional material.

The diagnostics which were described earlier, and which were the principal component of IIDA, detect quite specific errors or poor usage on the part of a searcher. The newer, Markovian measures are of general tendencies in the use of language. The two different measures appear to have different uses. Violation of an IIDA rule is a precise, correctable behavior. While we are not yet sure how to interpret deviation from the norm of a transition frequency distribution, we believe that such a distribution may represent a measure of general skill or sophistication in the use of a query language. This is yet to be proven conclusively.

One possible way of using the two forms of analysis together is that the Markovian analysis may be useful to provide a context which indicates to the system how the diagnostic information should be interpreted and acted upon. For example, if a future IIDA were to attempt to work with a broad range of users, certain diagnostic detectable behavior may be acceptable from a sophisticated user, but not from a novice. Use of the Markov analysis, in conjunction with the diagnostics, might provide a way of customizing, or fine-tuning, the system to the user. Perhaps the best example of this is the IIDA imposed restriction on the amount of typing done by a user. If a novice is searching, we tried to limit the amount of typing because it had been our experience that inexperienced searchers often type excessive numbers of records to avoid the intellectual work of using set definitions to reduce the size of sets. If, however, an experienced searcher exceeds the IIDA imposed limit, other explanations for exceeding the limit are both reasonable and probable. Thus, it would be nice to have the system sensitive enough to either relax the limit for more sophisticated searchers or not even send the searcher a message at all.

In the comparisons of the IIDA searchers with the Exxon professionals, the diagnostics showed no differences between the two groups. In addition, the end users' assessment of the value of the citations retrieved did not differ. However, the Markovian analysis did show a difference between the two groups. This suggests the possibility that the differences between the two groups were stylistic, reflecting the sophistication of the professional searchers. If this is the case then the possibility exists that

in some cases events that were recorded by the diagnostics as having been "errors" might well have been "errors of experience." These errors of experience being the kind of errors that result from knowing which principles or rules can be broken and when it is safe to do so.

9.2 Other Characteristics of a Search

Further analyses of state probability data are planned in an attempt to discover a basis for classifying entire searches into major segments according to the pattern of usage of commands. The objective is to enable an intelligent program to perceive what kind of user it is dealing with and to modify its own behavior accordingly. We do not expect that these new measures will replace command diagnostics. These further analyses are not part of the IIDA project, but we plan to use our IIDA data to test some of them out.

One procedure is to organize command probability data by rank order, following Zipf's work (21) with natural language. The command rank order distribution can be expected to follow approximately a negative exponential curve, as does natural language, with allowances for the small size of the samples (i.e., 10-20 commands, typically, compared with thousands of natural language words). On a semi-log scale this becomes a line whose slope and intercept then might be used to characterize the distribution. It is hoped that such characterization of searches might provide for accurate characterization of users by type.

Yet another measure to investigate, also suggested by Penniman, is Shannon's H (22) is applied to state probabilities. These investigations will be pursued after the conclusion of the IIDA project.

10. THE FUTURE OF COMPUTER ASSISTANTS

In this brief section we look into the future and try to project the role for systems like IIDA. IIDA is not the only system of its generic type and our projection is based on the future of the class, not the individual program. A commercial version of IIDA is being developed by the Franklin Institute Research Laboratories, Inc., of Philadelphia which organization participated in the IIDA project. The remainder of this section is devoted to a candidly subjective appraisal of the future potential of these systems.

We see IIDA as representative of a class of computer systems or system components whose purpose is to assist people in using other systems or components. Whether the assistant is a stand-alone program coupled with another stand-alone program (as are IIDA and CONIT), or a component designed to make the parent system easier to use, it is fast becoming recognized among designers of information systems that the computer, itself, can play a major role in assisting people to use it to fullest advantage.

10.1 Matching Users and Programs

Although designers of computer software systems such as FORTRAN, PL/I, DIALOG, or ORBIT do not customarily publish a statement defining the intended user group, experience with such systems leaves us with the impressions that:

1. Users are expected either to have formal training prior to use or to work through a professional intermediary, who is trained in system use and will perform the actual mechanical work for the end user.
2. In the case of information retrieval systems, not a great range of skill is expected. By comparison, general purpose programming languages have useful language subsets for the novice as well as special features that only the most skilled programmers use.

3. The proportion of the population who understand computers increases steadily and those who basically understand computers and who have mastered one language for dealing with them may feel impatient if they are required to go through a formal training course in order to program a simple task in a new language.

10.2 The Role of Intermediary Programs

We might, then divide the world of computer software, in terms of user interaction, into three parts: (1) the basic, work-producing systems, such as applications programs, information retrieval programs or statistical analysis programs; (2) the language processors through which users deal with the Type 1 programs; and (3) "front end" programs designed to enable people to use a program of Type 1 or 2.

Type 1 or 2 programs are typically "capital"--large, general purpose. If they were designed to be used with a Type 3 program--as modern computers are designed to be used with an operating system, unlike their older predecessors--their designers could concentrate on what the system can do, not on how to use it. Type 3 interface programs would take on the burden of enabling people to use the systems, and we can expect they will evolve with the capabilities to:

1. Effectively customize the Type 1 or 2 programs to suit the needs of the organization or individual using them. For example, if an organization's staff searches only one data base, an interface assistant would employ a user language particularized to that data base. On the other hand, CONIT represents an opposite approach. An organization using it could elect to use a common language for a wide range of search services and the intermediary computer performs the translation into the particular language of each service in a user-transparent manner.
2. Enable people to make meaningful use of Type 1 and 2 systems with only a minimum of prior training, and to adapt continuously to increased levels of user skills, thus enabling them to use as much of the target system's capabilities as they can at their individual states of training.

3. Serve as a focus for the local organization's training program in computer use and for assessment by the institution of how well its information systems are being used.

10.3 Impact of Intermediary Computers

As this concept, the customized intermediary assistant, becomes common, we can expect some changes in the way in which information systems are used locally and the way in which Type 1 and 2 programs are designed and marketed:

1. The potential user group, or market, for many kinds of programs will increase, including those now considered too technical or specialized for "general" users. For example, a system such as SPSS (Statistical Package for the Social Sciences) could be used by almost anyone who understands the statistics to perform analyses. There would be no need to learn the specifics of laying out records of input data, and the intermediary would help in determining which SPSS facility is best to employ for a given problem. The user would concentrate on statistics, not programming.
2. Designers and vendors of these programs can concentrate on their roles as capital tool producers and not on their role of fulfilling consumer needs. In many cases this can lead to more effective or efficient programs, as the large, centrally located programs are designed to process data efficiently and the slower user interface operations are carried out in local mini- or micro-computers.
3. More users will be attracted to use computers as the intimidating technical learning requirement lessens. We do not equate increased computer use necessarily with "good," but we do feel that many information systems are underutilized. Indeed, IIDA was originally conceived in response to a recognition that this was true in the restricted area of use of scientific and technical bibliographic information systems.

4. These intermediary computers have the capability to serve as multiplexors or concentrators (23), permitting several users to work simultaneously, sharing a single common line from the mini-computer to the target system. In the case of bibliographic searching, we estimate that four or five relatively inexperienced searchers can share a single line to a search service, especially if they work at 300 baud terminals while the intermediary-search service line operates at 1200 baud. While this would appear to be a great saving for users, the reality will certainly be that search services will change their price schedules. Still, the net effect can be a more efficient operation for both user and seller, hence less costly operation for both. One implication may be that information retrieval programs (Type 1) may have to be redesigned around the expectation of heavy shared use of communication lines.

In summary, we expect to see the customized intermediary computer become the common way to use large, complex, capital type programs. This will result both in more users of the latter systems and lower cost use. Both these effects--increasing breadth of use and decreasing cost--are typical of the effects of major changes in computer software over the years.

11. ACKNOWLEDGEMENTS

This has been a long project, involving many people to whom we take this opportunity to offer our appreciation and thanks.

Dr. Carol Ganz of the National Science Foundation helped us get started and showed continued support for the idea of IIDA.

Beth Krevitt Eres and Bernard Epstein of the Franklin Research Center helped initiate the project. Epstein has helped in many ways throughout. David E. Toliver joined while a graduate student at Drexel, then moved to Franklin and took over the computer programming for the entire project. Jan Edelmann also helped with computer programming. Ann Maher did our early work on computer assisted instruction.

Janet Chapman, Jean Rafsnider, Sari Scott and Jerry Warren, and co-author Elizabeth Aversa all were Drexel graduate research assistants on the project.

Dr. Carol H. Fenichel did her dissertation research as a part of the project.

Dr. Jerry Kidd, Barbara Lawrence, Richard S. Marcus and Dr. Linda M. Smith served as our advisory, or oversight, committee. They were a joy for us all to work with.

Richard Marcus, in addition, helped immeasurably by providing access to CONIT computer programs.

Barbara Lawrence, in addition, arranged for us to test IIDA at Exxon and arranged for the additional funding to make such a large scale test possible. Karen Landsberg and Pat Lorenz, among many others at Exxon, helped to set up and operate the evaluation studies.

Dr. Roger K. Summit, of Lockheed's Information Systems Program Office, provided technical help, continued interest, and access to DIALOG for the evaluation program.

John E. Creps, Jr., of Engineering Index, Inc., provided access to the Compendex data base for the evaluation.

Dr. Robert Rich, Princeton University, served as a consultant on evaluation.

12. IIDA BIBLIOGRAPHY

The publications listed below were produced in whole or in part as a result of work on this project. While all of the quarterly reports have been deposited with ERIC, they have not all, as yet, been processed, so some accession numbers are not given.

1. Meadow, Charles, T., et al.; Individualized Instruction for Data Access (IIDA), Final Design Report, NSF Grant No. DSI 76-9737, Philadelphia, Graduate School of Library Science, Drexel University, July 1977, ERIC Doc. No. ED 145 826.
2. Individualized Instruction for Data Access, Quarterly Report No. 1, NSF Grant No. DSI 77-26524, Philadelphia, School of Library and Information Science, Drexel University and Franklin Research Center, June 1978, ERIC Doc. No. ED 168 462.
3. _____, Quarterly Report No. 2, September 1978, ERIC Doc. No. ED190 080.
4. _____, Quarterly Report No. 3, December 1978 ERIC Doc. No. ED 190 080.
5. _____, Quarterly Report No. 4, March 1979, ERIC Doc. No. ED 179 195.
6. _____, Quarterly Report No. 5, June 1979, ERIC Doc. No. ED 190 081.
7. _____, Quarterly Report No. 6, September 1979, ERIC Doc. No. ED 190.081.
8. _____, Quarterly Report No. 7, December 1979, ERIC Doc. No. ED 191 506.

9. _____, Quarterly Report No. 8, March 1980, ERIC Doc. No. ED 201 340.
10. Meadow, Charles T. and Bernard Epstein, "Individualized Instruction for Data Access," On-line Information Meeting, London, 13-15, December 1977, Learned Information, Oxford and New York, 1978, pp. 179-94.
11. Meadow, Charles T., David E. Toliver and Janet V. Edelman, "A Technique for Machine Assistance to Online Searchers," Proceedings of the ASIS Annual Meeting, 1978, Vol. 15, White Plains, NY, Knowledge Industry Publications, 1978, pp. 222-5.
12. Meadow, Charles T., "Online Searching and Computer Programming: Some Behavioral Similarities," Online 3,1, January 1979, 49-52.
13. _____, "The Computer as a Search Intermediary," Online, 3,3, July 1979, 54-59.
14. Toliver, David E., "A Program for Machine-Mediated Searching," Information Processing and Management, to be published 1980.
15. Fenichel, Carol Hansen, Online Information Retrieval: Identification of Measures that Discriminate Among Users with Different Levels and Types of Experience, Ph.D. dissertation, School of Library and Information Science, Drexel University, Philadelphia, 1979.
16. Hewett, Thomas T. and Charles T. Meadow, "Measurement of User Performance," 17th Annual Clinic on Library Applications of Data Processing, University of Illinois, Urbana, IL, 1980.
17. Landsberg, Karen, et al., "A Joint Industrial-Academic Experiment: An Evaluation of the IIDA System," Proceedings of the ASIS Annual Meeting, 1980, Vol. 17, White Plains, NY, Knowledge Industry Publications, 1980.
18. Meadow, Charles T., Thomas T. Hewett and Elizabeth S. Aversa, Individualized Instruction for Data Access, Final Report, NSF Grant No. DSI 77-26524, Philadelphia, School of Library and Information Science, Drexel University, June 1980.

13. REFERENCES

1. Allen, T.J. "Organizational Aspects of Information Flow in Technology," ASLIB Proceedings, Vol. 20, No. 2, 1968.
2. Meadow, Charles T. "The Computer as a Search Intermediary," Online (July, 1979) 54-59.
3. Goldstein, C.M. and W.H. Ford. "The User-Cordial Interface," Online Review, 2,3 (September, 1978) 269-275.
4. Individualized Instruction for Data Access (IIDA), Quarterly Report No. 6, NSF Grant No. DSI 77-26524, Philadelphia, Drexel University School of Library and Information Science and Franklin Research Center, September, 1979. ERIC Doc. No. ED 190 081
5. Ibid.
6. Individualized Instruction for Data Access (IIDA), Quarterly Report No. 5, NSF Grant No. DSI 77-26524, Philadelphia, Drexel University School of Library and Information Science and Franklin Research Center, June 1979. ERIC Doc. No. ED 190 081
7. Individualized Instruction for Data Access (IIDA), Quarterly Report No. 4, NSF Grant No. DSI 77-26524, Philadelphia, Drexel University School of Library and Information Science and Franklin Research Center, March 1979. ERIC Doc. No. ED 179 195
8. Hewett, Thomas T. and Charles T. Meadow. "Measurement of User Performance," paper presented at the 17th Annual Clinic on Library Applications of Data Processing, University of Illinois, Urbana, Illinois, April, 20-25, 1980.
9. Individualized Instruction for Data Access (IIDA), Quarterly Report No. 6.
10. Ibid.

11. Grignetti, Mario C., Catherine Hausmann, and Laura Gould. "An 'Intelligent' On-Line Assistant and Tutor--NLS Scholar," National Computer Conference Proceedings (1975) 775-781.
12. Brown, John Seely, Richard R. Burton, and Alan G. Bell. "SOPHIE: A Step Toward Creating a Reactive Learning Environment," International Journal of Man-Machine Studies, 7/(1975), 675-696.
13. Marcus, Richard S. and J.F. Reintjes. Computer Interfaces for User Access to Heterogeneous Information Retrieval Systems, Massachusetts Institute of Technology Electronic Systems Laboratory Report ESL-R-739, Cambridge, Massachusetts, April 1977.
14. Caruso, D. Elaine. "Hands on Online: Bringing it Home," Online Review, 3, (September 1978).
15. Penniman, William David. Rhythms of Dialogue in Human-Computer Conversation, Ph.D. Dissertation, The Ohio State University, 1975.
16. Standera, Oldrich. "Online Retrieval Systems: Some Observations on the User System Interface," Information Revolution: Proceedings of the 38th Annual ASIS Meeting (1975).
17. Individualized Instruction for Data Access (IIDA), Quarterly Report No. 7, NSF Grant No. DSI 77-26524, Philadelphia, Drexel University School of Library and Information Science and Franklin Research Center, December 1979. ERIC Doc. No. ED 191 506
18. Individualized Instruction for Data Access (IIDA), Quarterly Report No. 8, NSF Grant No. DSI 77-26524, Philadelphia, Drexel University School of Library and Information Science and Franklin Research Center, March 1980. ERIC Doc. No. ED 201 340
19. Penniman (15).

20. Chapman, Janet. "A State Transition Analysis of Online Information-Seeking Behavior," unpublished paper, Drexel University School of Library and Information Science, Philadelphia, 1980.
21. Zipf, George K. Human Behavior and the Principle of Least Effort. Cambridge, Massachusetts: Addison-Wesley, 1949.
22. Shannon, Claude E. and Warren Weaver. The Mathematical Theory of Communication. Urbana, Illinois: University of Illinois Press, 1959.
23. Individualized Instruction for Data Access (IIDA), Final Design Report, NSF Grant No. DSI 76-09737, Philadelphia, Drexel University School of Library and Information Science and Franklin Research Center, July 1977.
24. Fenichel, Carol Hansen. Online Information Retrieval: Identification of Measures That Discriminate Among Users with Different Levels and Types of Experience. Ph.D. dissertation, School of Library and Information Science, Drexel University, Philadelphia, 1979.
25. A Guide to DIALOG Searching, Lockheed DIALOG Information Retrieval Service, Palo Alto, California, 1979.